

BUILDING  
INSTRUCTIONS



# INTRODUCTION



Thank you for purchasing the Tekno RC EB410 1/10th Scale 4WD Competition Electric buggy kit. We are always working on new projects, so please **REGULARLY** check our website at [www.teknorc.com](http://www.teknorc.com) or our Facebook page at [www.facebook.com/teknorc](http://www.facebook.com/teknorc) for the latest news, parts, and kits.

Take your time! When you work your way through these building instructions, keep an eye out for the following important indicators below:

- **RED TEXT** - *This indicates important areas of the build process that should be observed.*



## Thread Lock icons

Thread lock is always used when a screw is inserted into any metal part. (Included with kit)



## Grease icons

Grease is usually used on areas with movement and for sealing. (Included with kit)

- **YOUTUBE** - *We also have many useful build videos on Youtube, so be sure to check these out!*  
<https://www.youtube.com/c/teknorc>

## Additional equipment and parts needed:

- 2 Channel radio and receiver
- 1/10th scale ESC and motor system
- Low profile or standard size high torque steering servo (at least 150 oz/in)  
\* **Running less than the recommended rating will increase the chance of premature servo failure.**
- 2S (2 cell, 7.4v) shorty LiPo battery
- Paint for body
- 1/10th scale 4x4 buggy wheels & tires, CA glue (or premounts)
- 48 pitch pinion 15 tooth - 30 tooth

## Tools needed:

- Hex drivers 1.5mm (TKR1104), 2.0mm (TKR1105), 2.5mm (TKR1106)
- Nut drivers 5.5mm (TKR1108), 7.0mm (TKR1109)
- Hobby knife
- Needle-nose pliers
- Shock tool (TKR1115) OR adjustable (Crescent) wrench (for shock assembly)
- 4mm turnbuckle wrench (TKR1103) AND 5.5/7.0 two sided wrench (TKR1119)
- 1/16th (or 1.6mm) drill bit for shock cap emulsion hole
- Body reamer

**Disclaimer:** Tekno RC is not responsible or liable for any property or personal damage, loss, or injury incurred as a result of using this product. This kit is meant for use by persons 14 years of age or older and in the strict confines of a legally permitted RC track or facility.

**Warnings:** Always double-check that your radio gear is working properly before operating vehicle. Never operate the vehicle indoors (unless the RC track is an indoor facility). Use caution while operating vehicle so as not to collide with people who may be turn marshalling or who might otherwise not be aware that a fast moving RC vehicle is in the vicinity.

**Warranty:** We warrant that the parts included in this kit are free from defects. If you find a defective part in your kit, please contact us @ [info@teknorc.com](mailto:info@teknorc.com) and we will help you to resolve the issue. We do not warranty parts that may be broken during operation of the vehicle or otherwise. Refer to the end of this instruction manual for a listing of spare/replacement and option parts. All spare parts and other info are available on our website ([www.teknorc.com](http://www.teknorc.com)) and through our network of domestic and international dealers and distributors.

# Bag A

## Center Differential (overview)

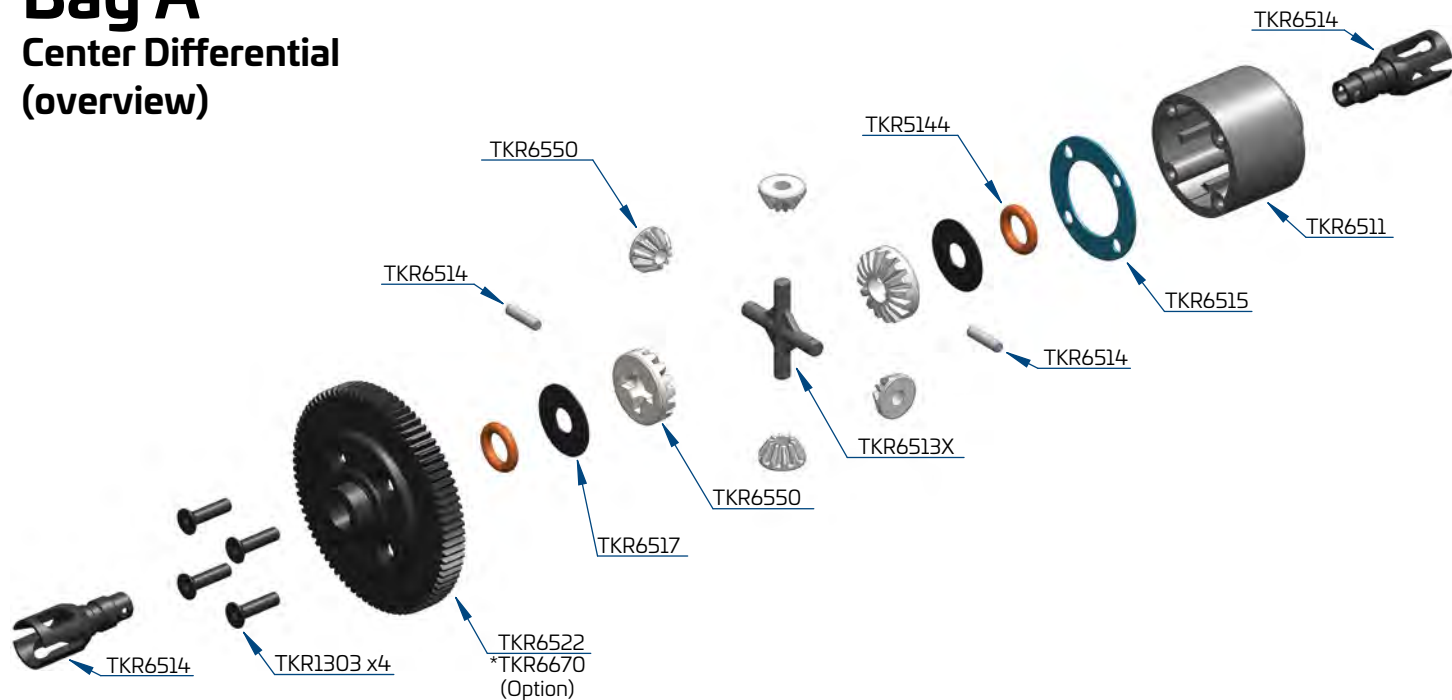

### Step A-1



### Step A-2

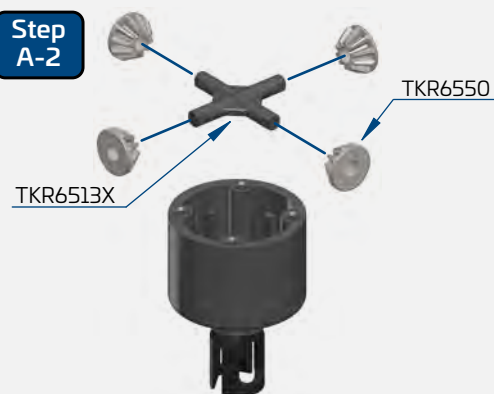

### Step A-4



### Step A-3



Fill with #15,000 oil to 1mm below full  
DO NOT OVER FILL

x4  
TKR1303  
M2.5x10mm Flat Head Screw

x2  
TKR5144  
Differential O-rings

x2  
TKR6517  
Differential Shims (5x14mm)

# Bag B

## Front and Rear Differential (overview)

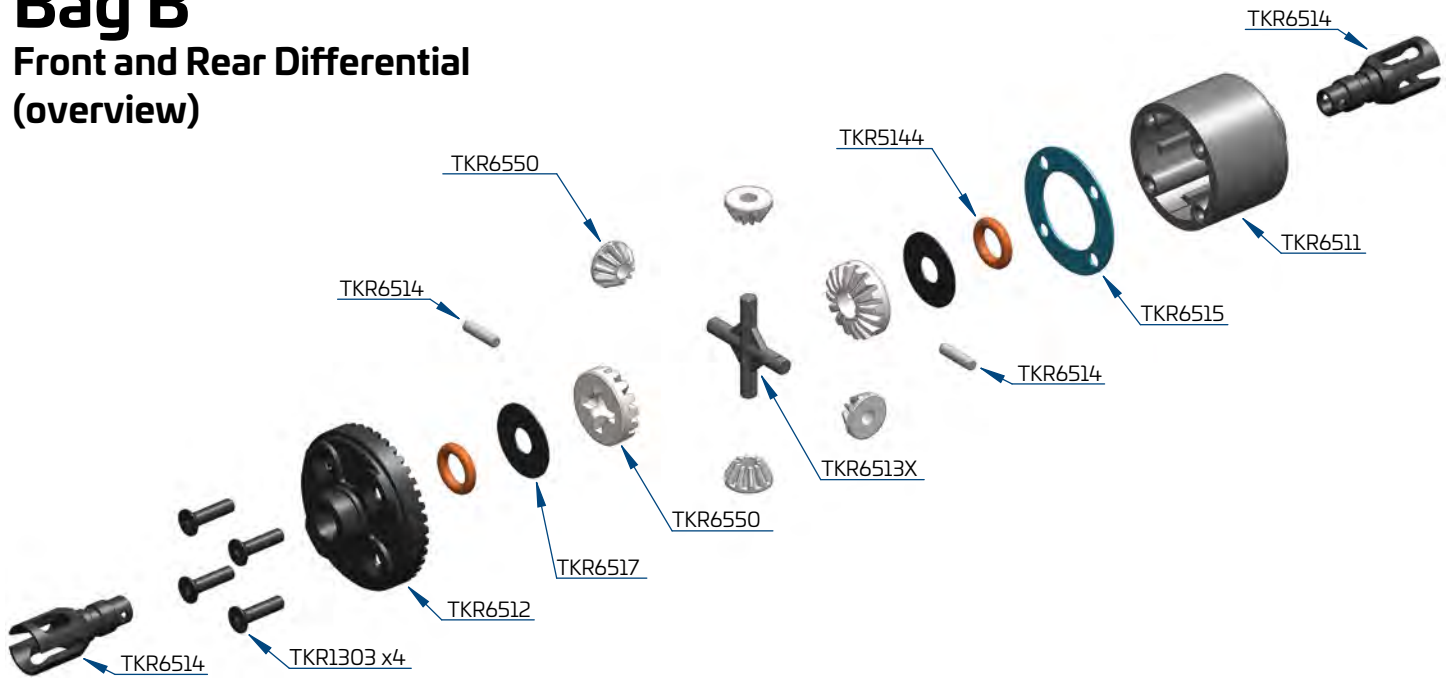

### Step B-1

Repeat for rear diff



Note: Apply grease to the groove where the o-ring is placed as well as the o-ring itself.

Note: Apply grease to the groove in the outdrive.

### Step B-2

Repeat for rear diff

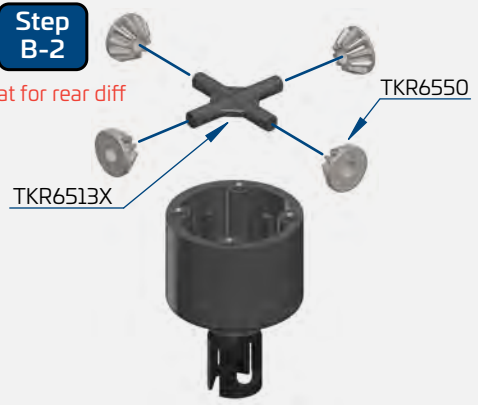

### Step B-4

Repeat for rear diff



### Step B-3

Repeat for rear diff

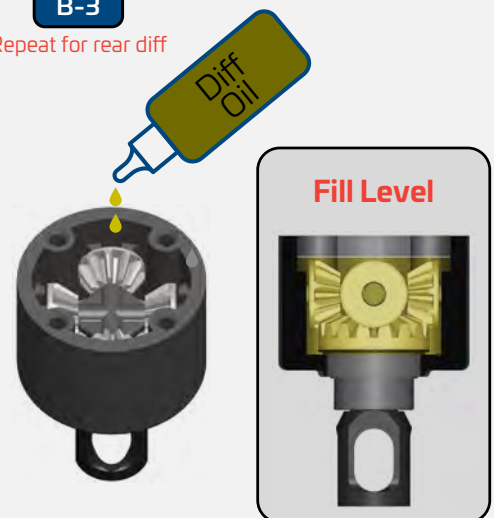

Fill FRONT with #15,000 oil  
Fill REAR with #7,000 oil  
to 1mm below full  
DO NOT OVER FILL

-  x8  
TKR1303  
M2.5x10mm Flat Head Screw
-  x4  
TKR5144  
Differential O-rings
-  x4  
TKR6517  
Differential Shims (5x14mm)

# Bag C

## Steering Assembly

(overview)

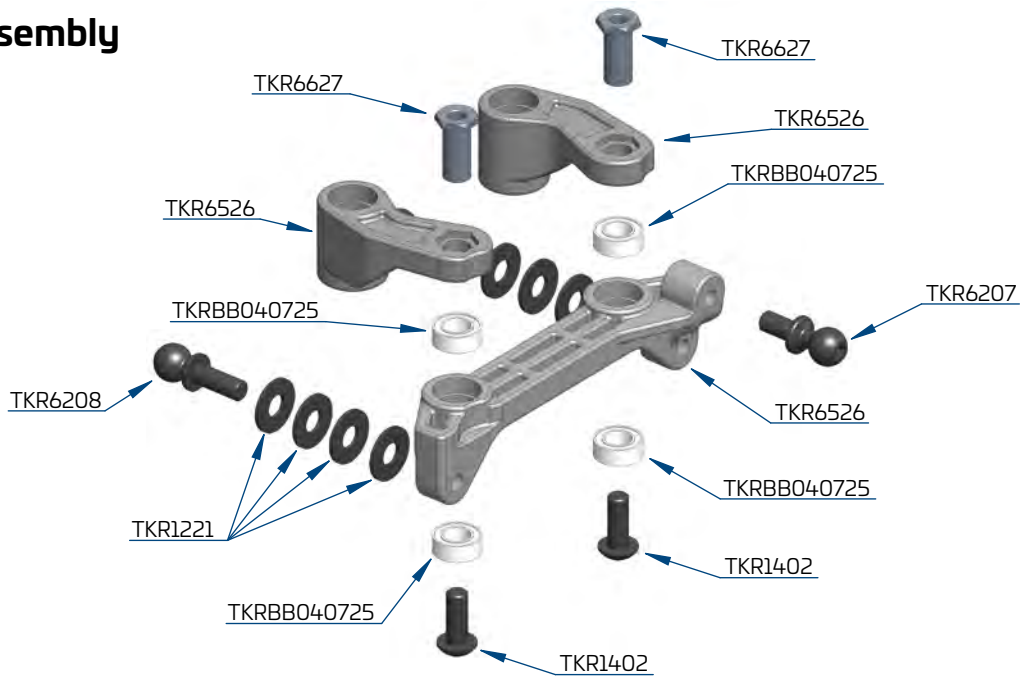

**Step C-1**

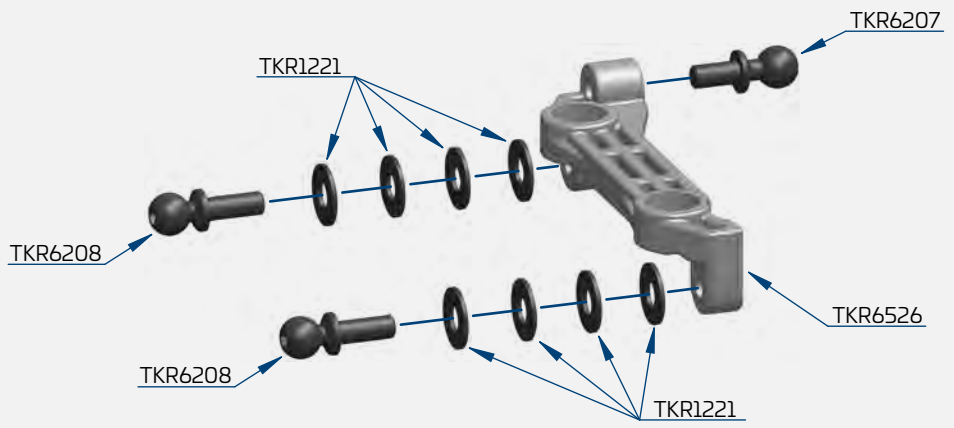

**Step C-2**

Note: Push these steering rack bushings hard into place until they click into the bellcranks.

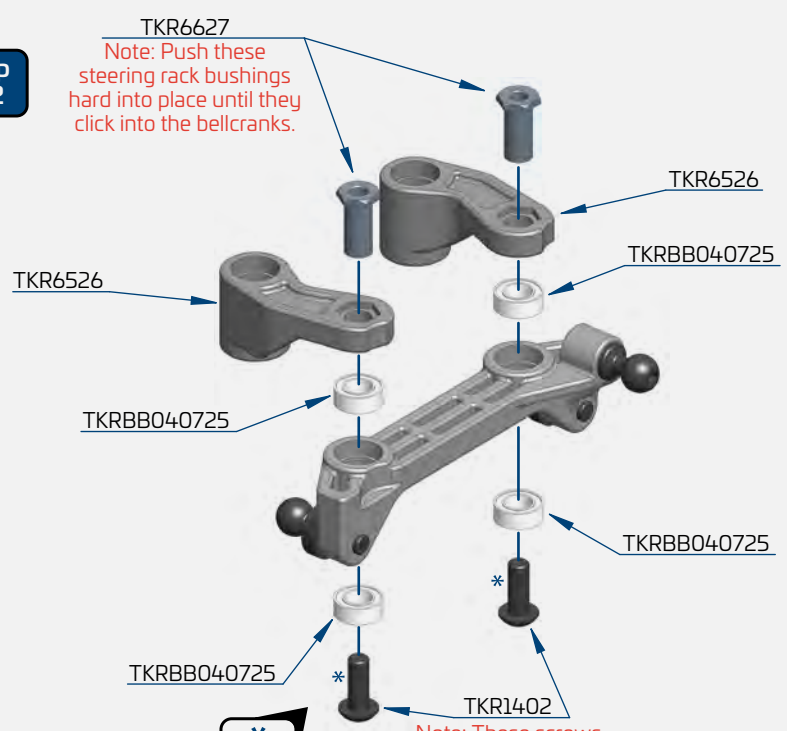

\* Thread Lock

Note: These screws only needs to be snug. Do not overtighten.

x8  
TKR1221  
M3x8mm Washer

x2  
TKR1402  
M3x8mm Button Head Screw

x1  
TKR6207  
M3x6mm Ball Stud

x2  
TKR6208  
M3x8mm Ball Stud

x4  
TKRBB040725  
Ball Bearing (4x7x2.5)

# Bag C

## Front Bulkhead Assembly (overview)

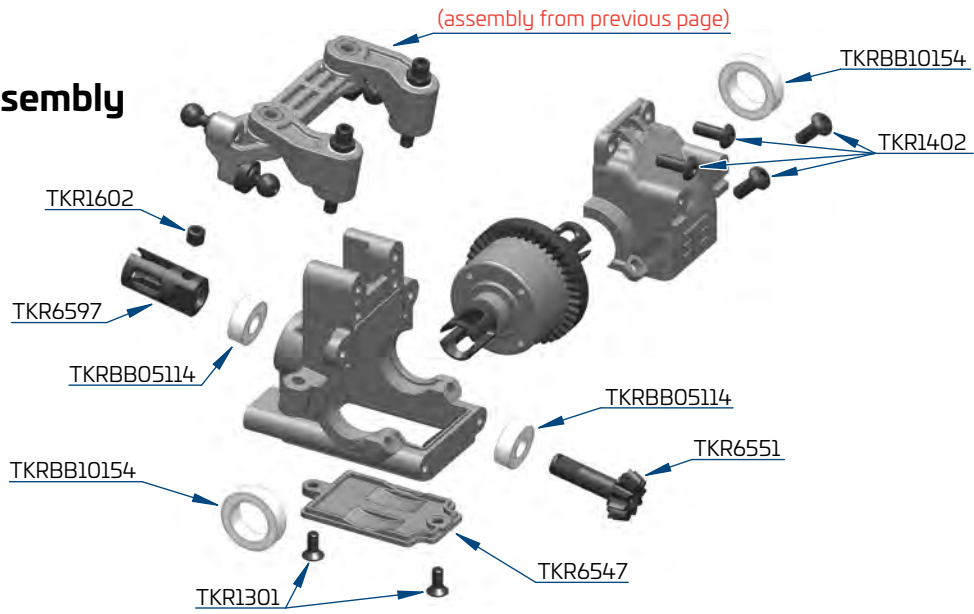

### Step C-3

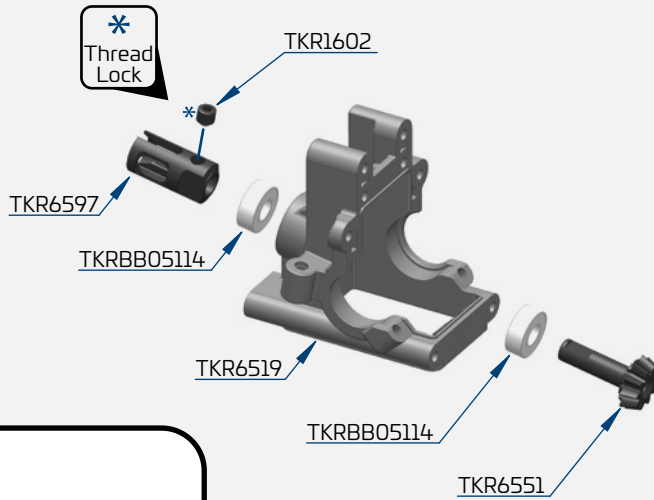

### Step C-4

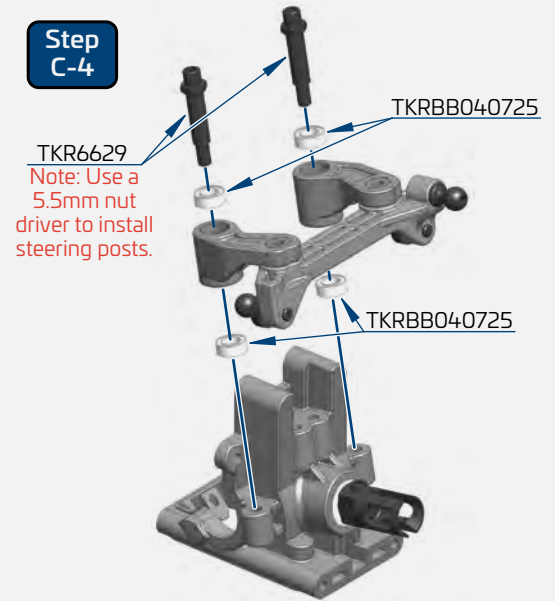

x2  
TKR1301  
M2.5x6mm Flat Head Screw

x4  
TKR1402  
M3x8mm Button Head Screw

x1  
TKR1602  
M4x4mm Set Screw

x4  
TKRBB040725  
Ball Bearing (4x7x2.5)

x2  
TKRBB05114  
Ball Bearing (5x11x4)

x2  
TKRBB10154  
Ball Bearing (10x15x4)

### Step C-5

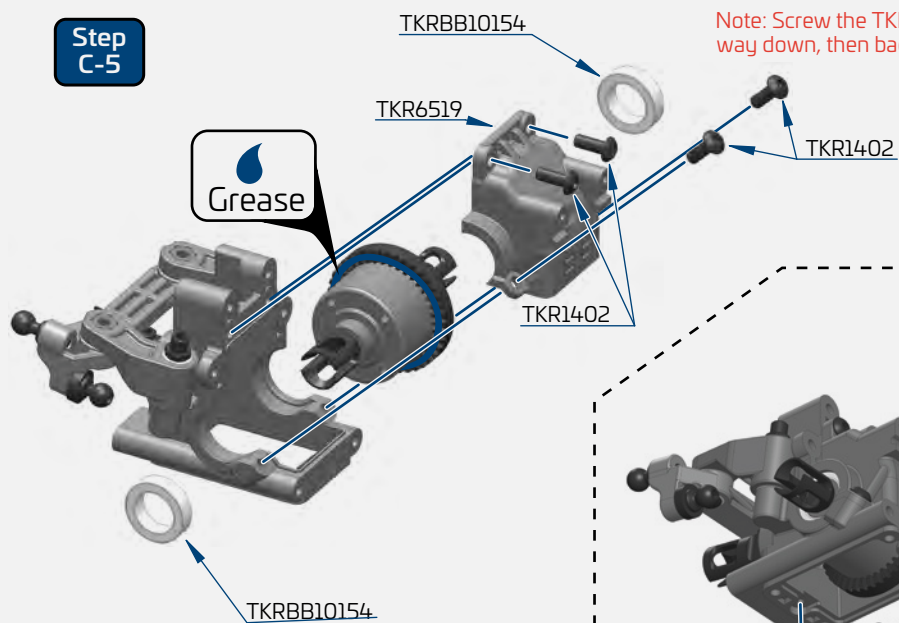

Note: Screw the TKR1402's all the way down, then back off 1/4 turn.

### Step C-6

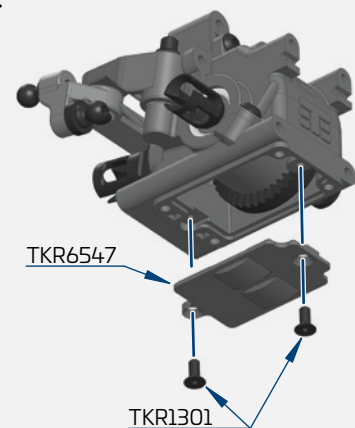

# Bag D

## Rear Bulkhead/ Wing Mount Assembly (overview)

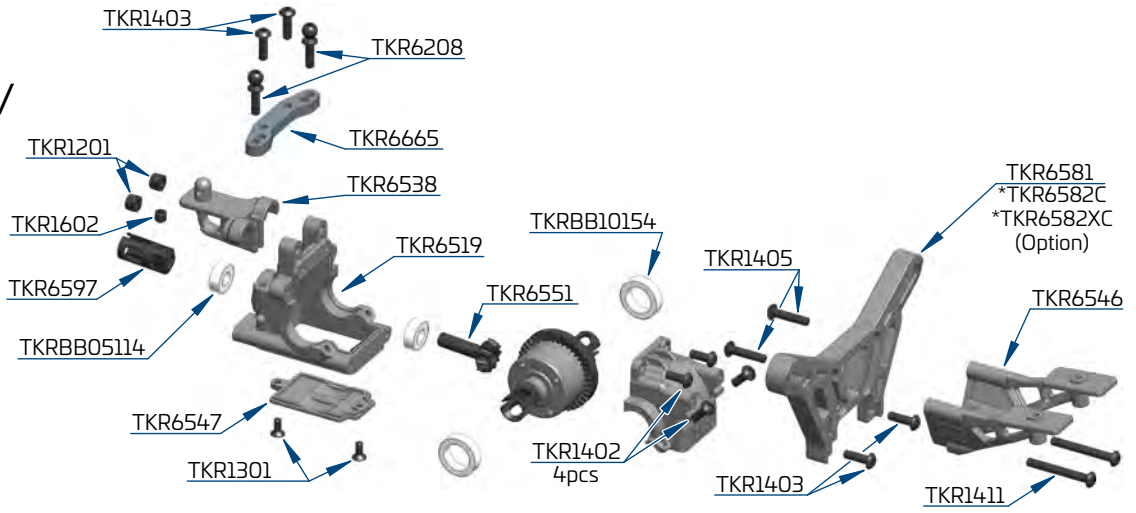

### Step D-1

\* Thread Lock

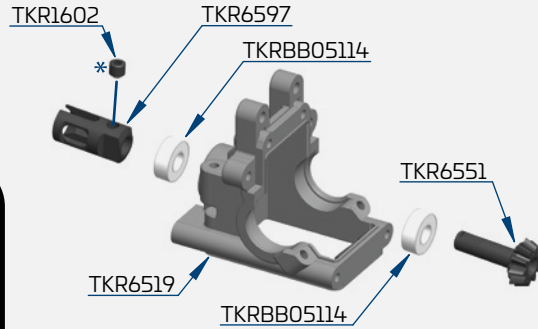

### Step D-2

\* Thread Lock

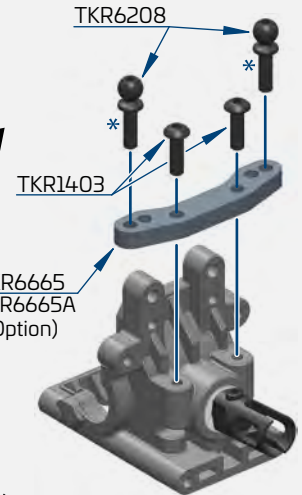

### Step D-3

Note: Screw the TKR1402's all the way down, then back off 1/4 turn.

Grease

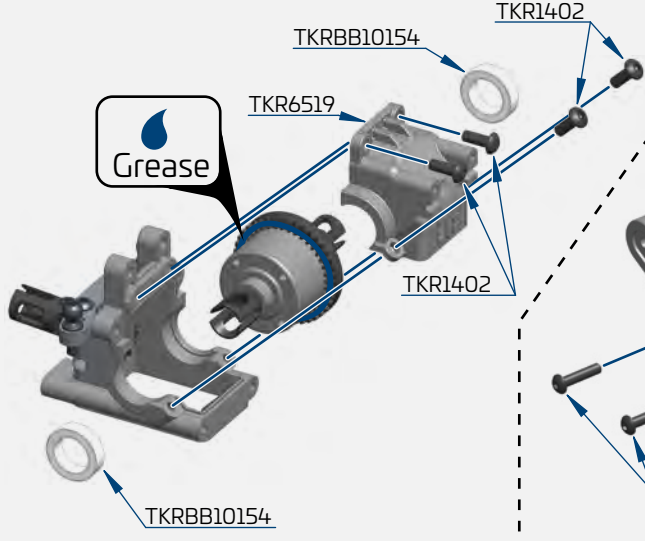

### Step D-4

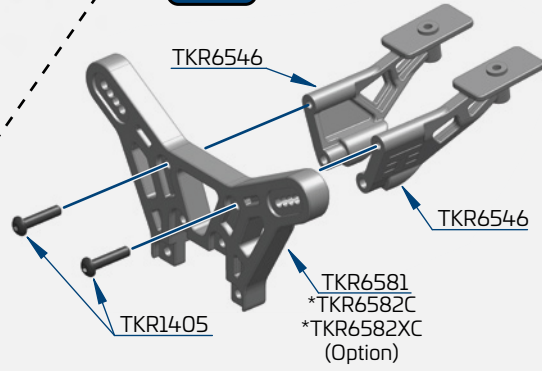

### Step D-5

Build Tip: Apply a bit of CA glue to help keep these nuts in place during maintenance and rebuilds.

CA Glue

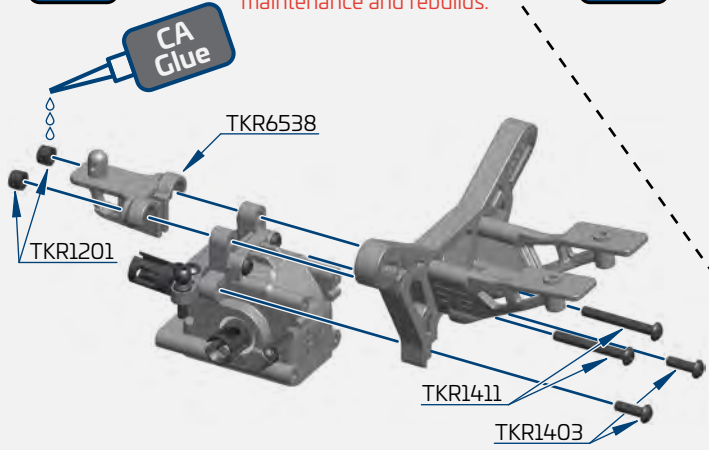

### Step D-6

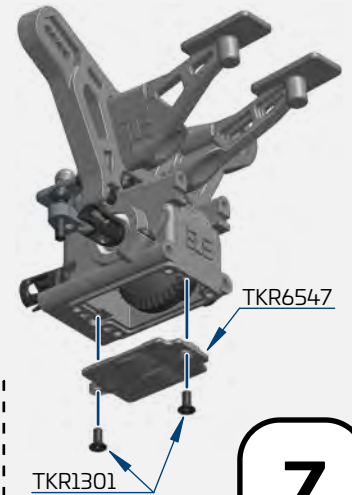

x2

TKR1201  
M3 Locknut Black

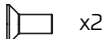

x2

TKR1301  
M2.5x6mm Flat Head Screw



x4

TKR1402  
M3x8mm Button Head Screw

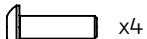

x4

TKR1403  
M3x10mm Button Head Screw



x2

TKR1405  
M3x14mm Button Head Screw

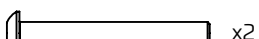

x2

TKR1411  
M3x25mm Button Head Screw



x1

TKR1602  
M4x4mm Set Screw

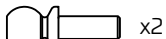

x2

TKR6208  
M3x8mm Ball Stud



x2

TKRBB05114  
Ball Bearing (5x11x4)



x2

TKRBB10154  
Ball Bearing (10x15x4)

# Bag E

## Rear End Assembly

Step E-1

TKR6610 - 1.7mm  
 Below options sold separately.  
 \*TKR6610 - 1.5mm  
 \*TKR6610 - 1.6mm  
 \*TKR6610 - 1.8mm  
 \*TKR6610 - 1.9mm  
 (Option)

TKR1601  
 Note: Do not over-tighten.



Step E-2

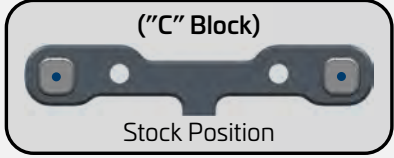

Note: With these center dot inserts, Anti-Squat = 2°

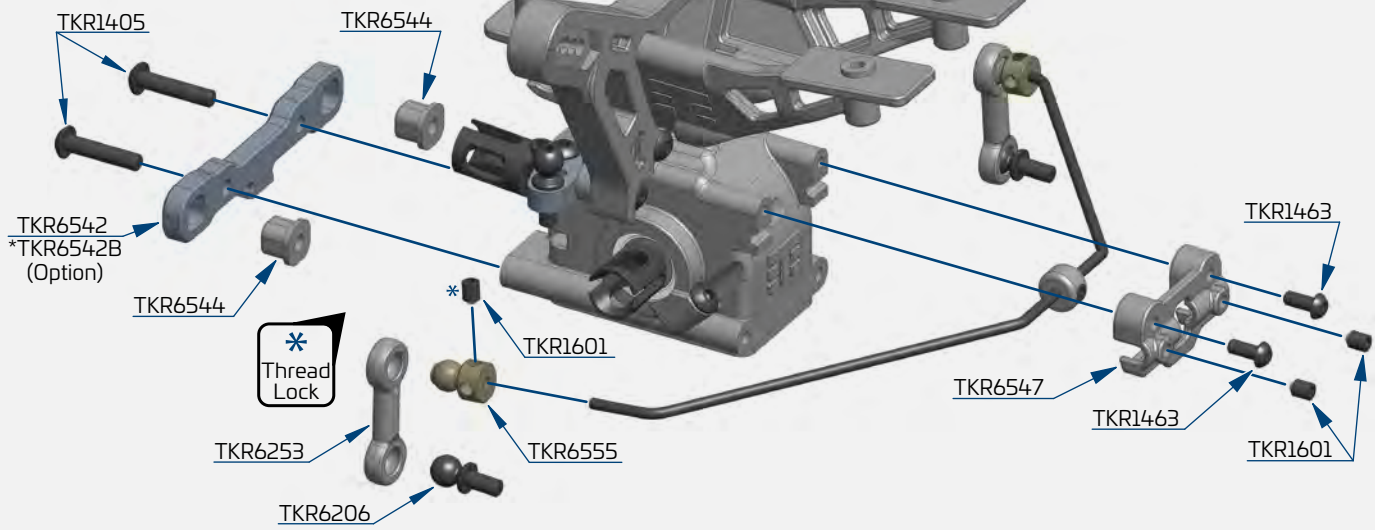

\* Thread Lock

Step E-3

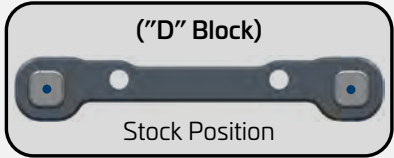

Note: With these center dot inserts, Rear Toe = 1.5°

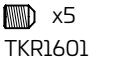
-  x4  
TKR1405  
M3x14mm Button Head Screw
-  x2  
TKR1463  
M2.5x6mm Button Head Screw
-  x5  
TKR1601  
M3x4mm Set Screw
-  x2  
TKR1611  
M4x8mm Set Screw
-  x2  
TKR6206  
M3x6mm Ball Stud

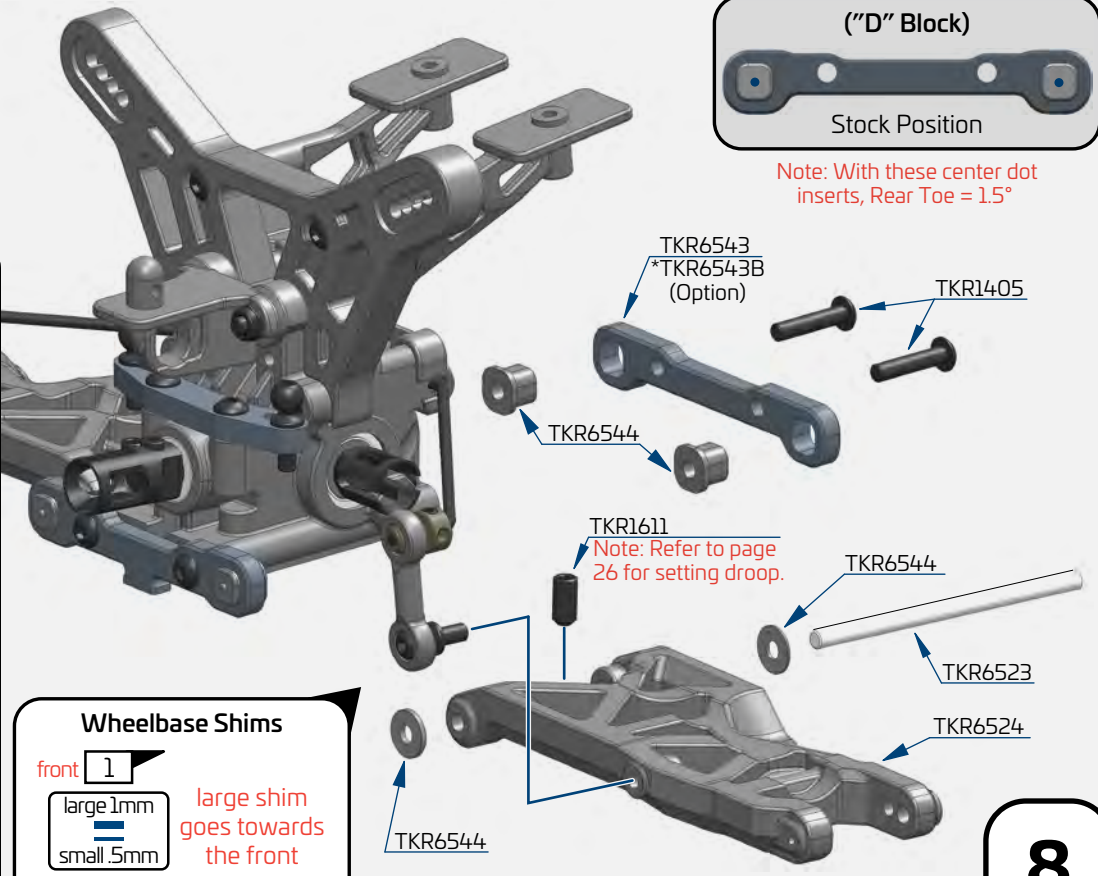

TKR1611  
 Note: Refer to page 26 for setting droop.

**Wheelbase Shims**

front	1	large shim goes towards the front
	large 1mm	
	small .5mm	
rear	.5	



# Bag F

## Rear Hub/CVA Assembly

Step F-1

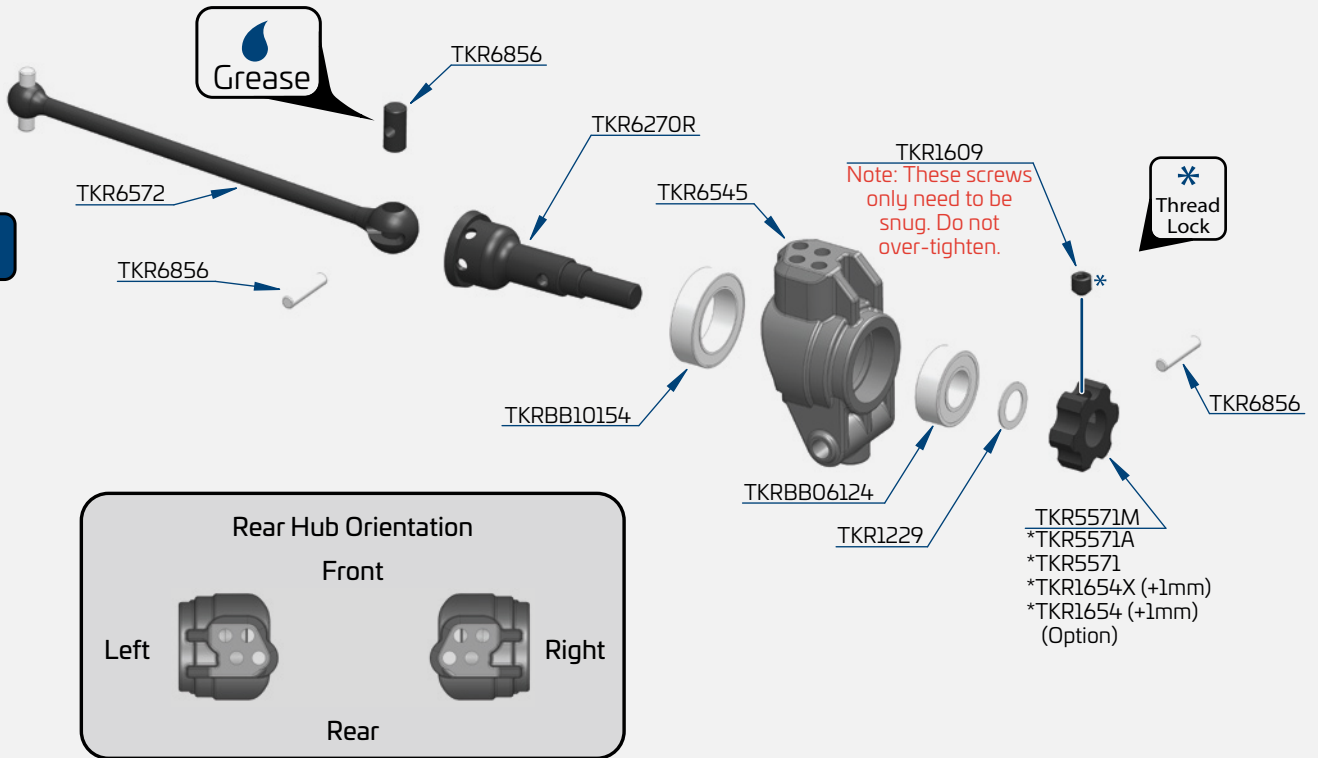

Step F-2



x2

TKR1229  
6x10x0.2mm Shim



x2

TKR1400  
M3x4mm Button Head Screw



x2

TKR1601  
M3x4mm Set Screw



x2

TKR1609  
M3x3mm Set Screw



x2

TKRBB06124  
Ball Bearing (6x12x4)



x2

TKRBB10154  
Ball Bearing (10x15x4)

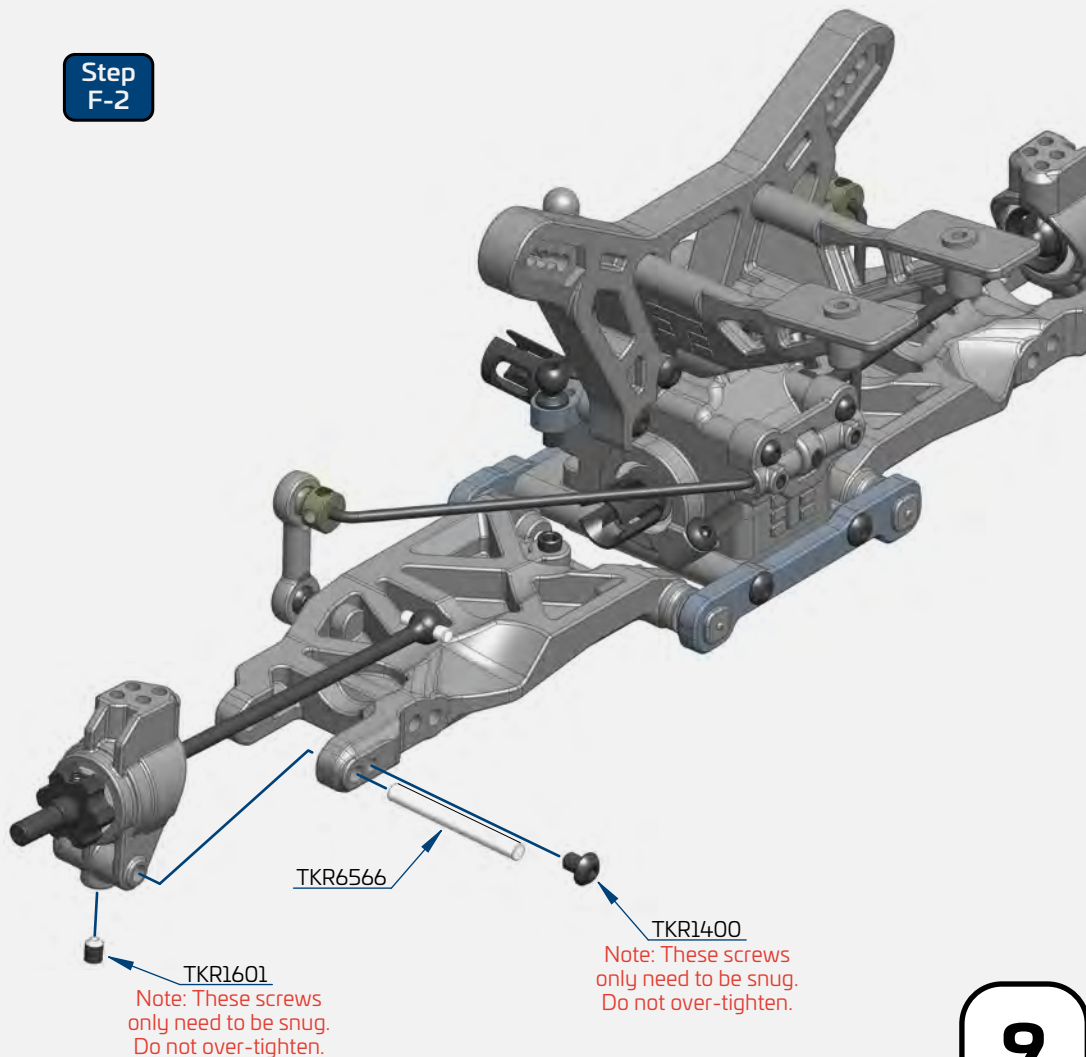

# Bag F

## Rear Camber Links



TKR6253

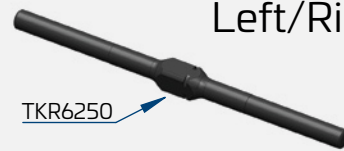

TKR6250

Left/Right x 2pcs



TKR6253

**Build Tip:** Use some grease or Chapstick on the threads to help prevent "pop-off" when adjustments are being made.

**Build Note:** Hold the turnbuckle stationary with pliers and push the rod end hard onto the turnbuckle while turning at the same time. Keep in mind that one end of the turnbuckle has normal threads and the other has reverse threads. Start the rod end straight and it will thread on straight.

Step F-3

Step F-4

Note: Notch always goes on left side of vehicle.

Actual Size



Note: Always press on with T logo visible.

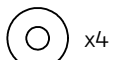
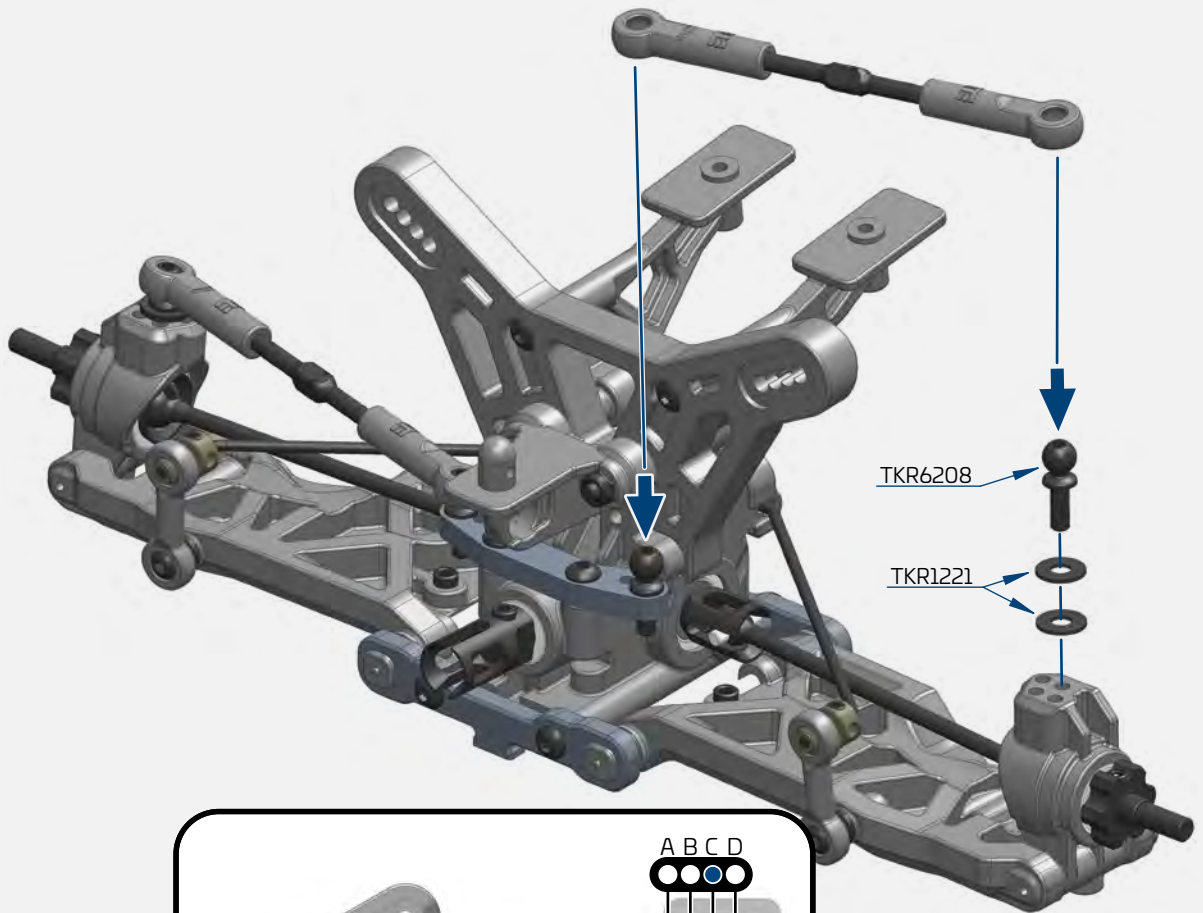

x4  
TKR1221  
M3x8mm Washer

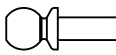

x2  
TKR6208  
M3x8mm Ball Stud

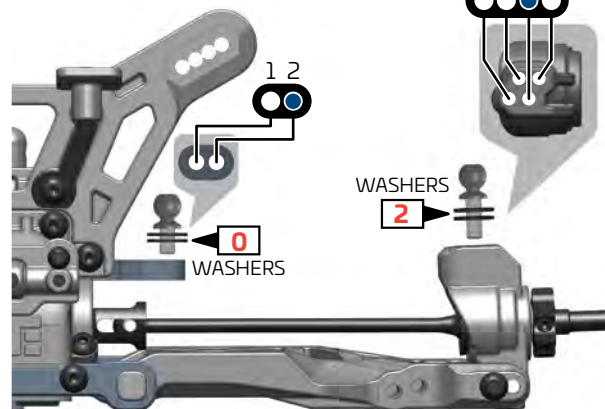

Stock position is 2/C

# Bag G

## Front End Assembly

Step  
G-1

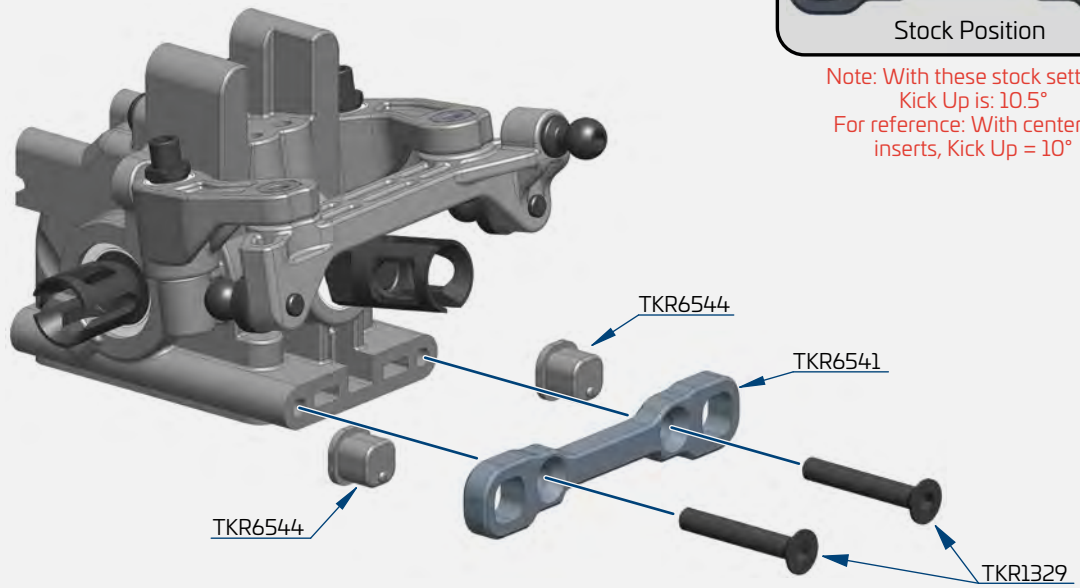

Note: With these stock settings,  
Kick Up is: 10.5°  
For reference: With center dot  
inserts, Kick Up = 10°

Step  
G-2



Note: With these center dot  
inserts, Arm Sweep = 0°

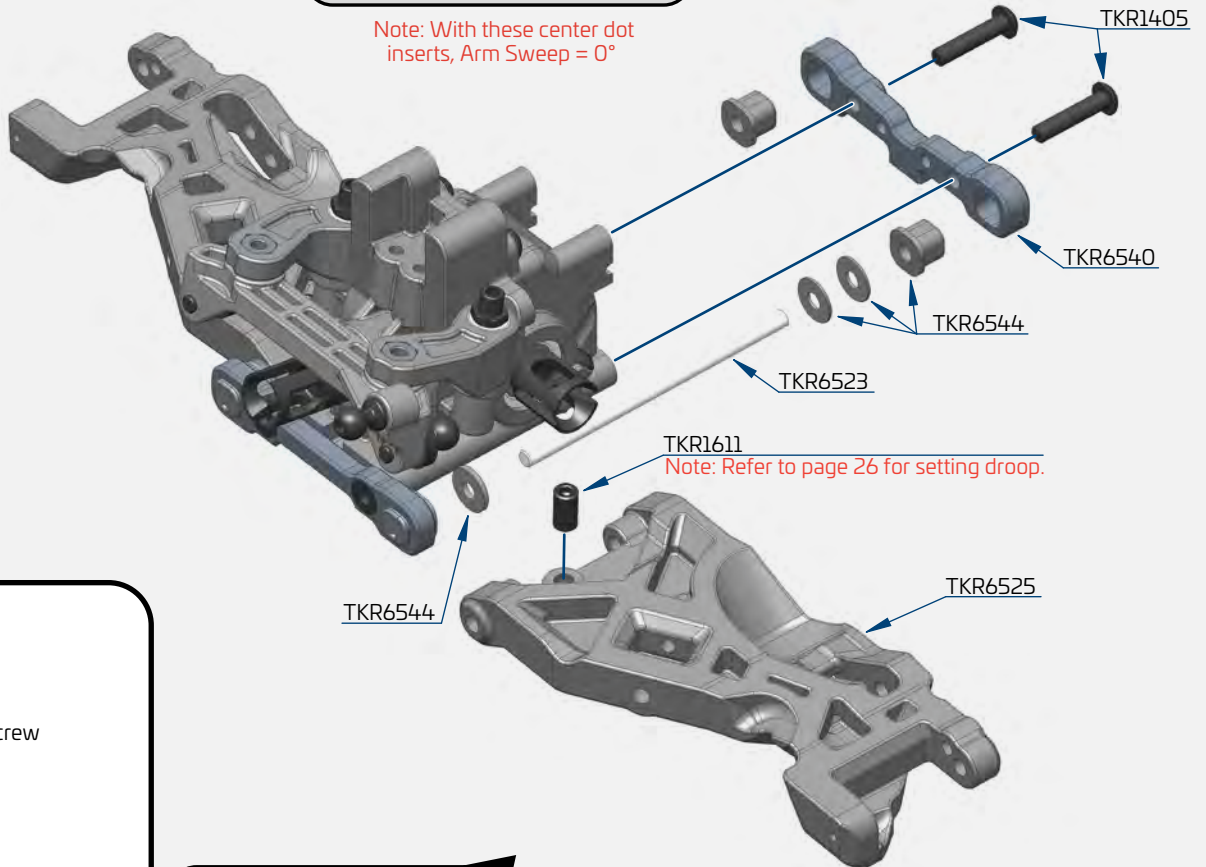

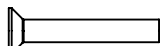

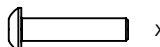
 x2  
TKR1329  
M3x20mm Flat Head Screw

 x2  
TKR1405  
M3x14mm Button Head Screw

 x2  
TKR1611  
M4x8mm Set Screw

### Wheelbase Shims

front  1  
large 1mm  
small .5mm  
rear  1  
large shim  
goes towards  
the rear

# Bag H

## Front Spindle/CVA Assembly

Step H-1

**DO NOT SKIP THIS STEP!**

Note: These are steering stop screws. They provide a mechanical limit to the steering throw and make the car easier to drive by greatly improving the consistency of the steering.

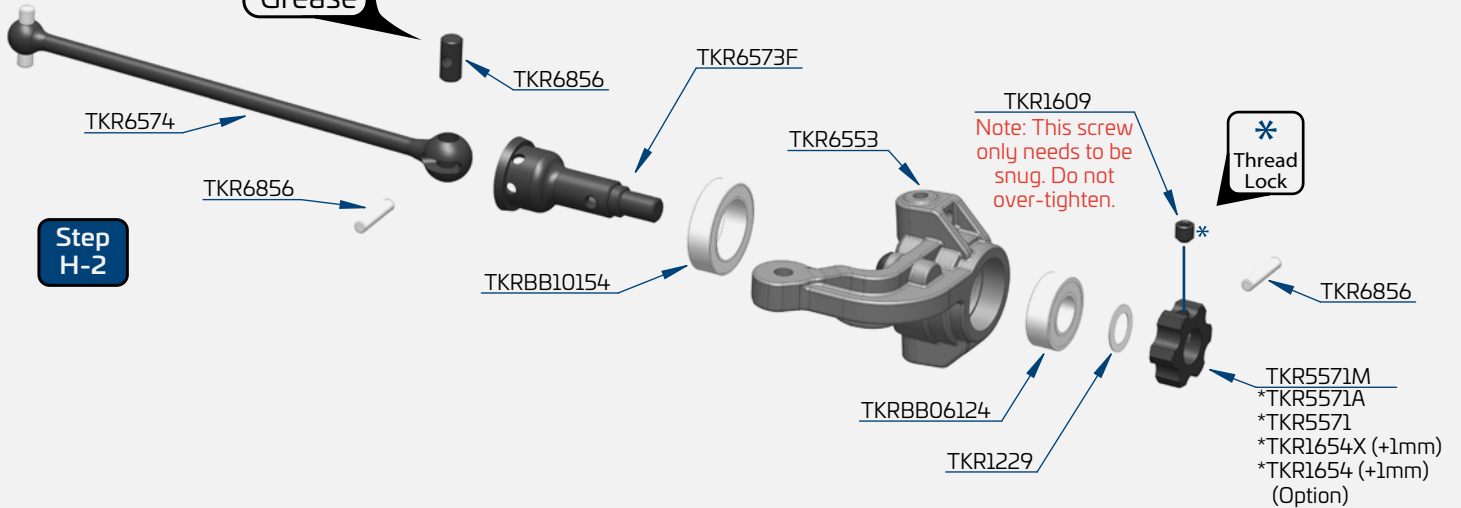
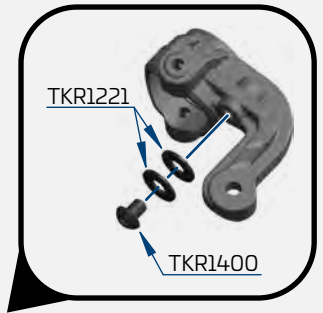

Step H-2

x4  
TKR1221  
M3x8mm Washer

x2  
TKR1229  
6x10x0.2mm Shim

x4  
TKR1400  
M3x4mm Button Head Screw

x5  
TKR1601  
M3x4mm Set Screw

x7  
TKR1609  
M3x3mm Set Screw

x2  
TKRBB06124  
Ball Bearing (6x12x4)

x2  
TKRBB10154  
Ball Bearing (10x15x4)

Step H-3

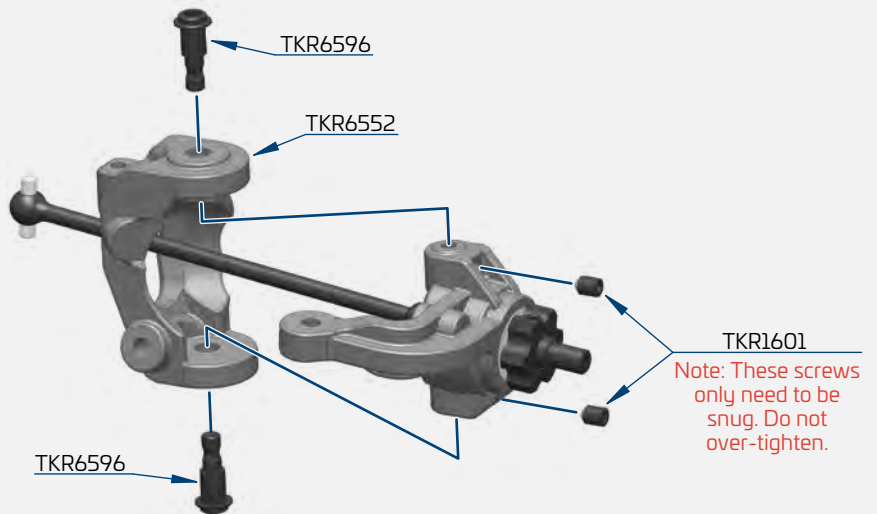

TKR1601  
Note: These screws only need to be snug. Do not over-tighten.

Step H-4

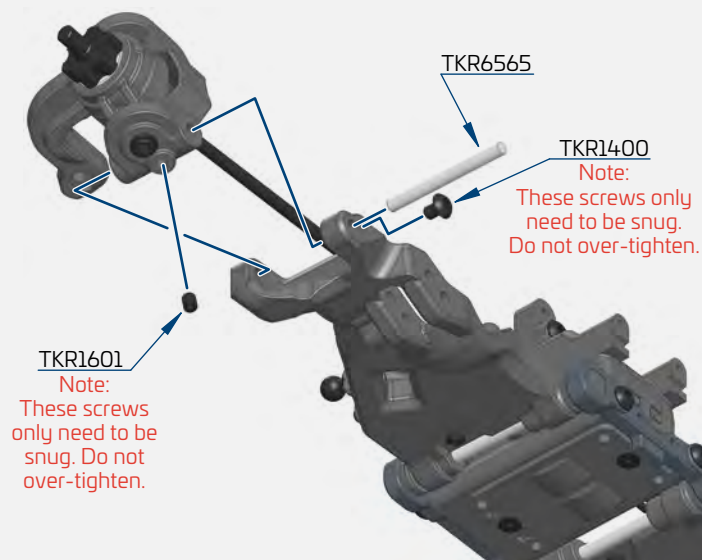

TKR1601  
Note: These screws only need to be snug. Do not over-tighten.

TKR1400  
Note: These screws only need to be snug. Do not over-tighten.

# Bag H

## Steering Links

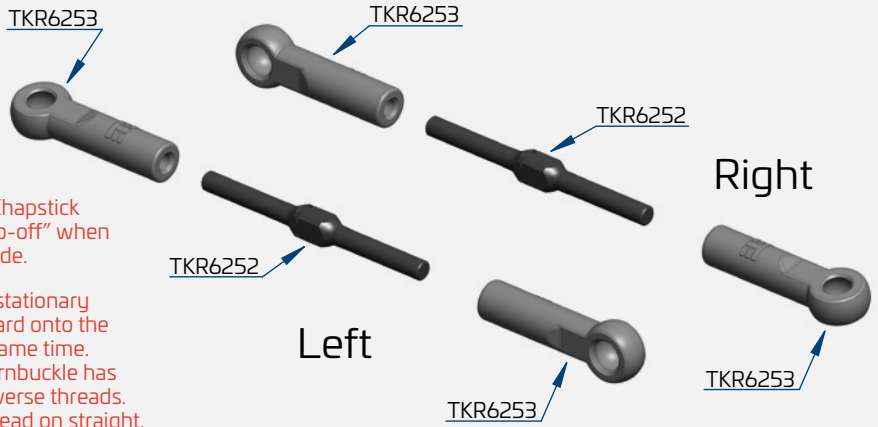

**Build Tip:** Use some grease or Chapstick on the threads to help prevent "pop-off" when adjustments are being made.

**Build Note:** Hold the turnbuckle stationary with pliers and push the rod end hard onto the turnbuckle while turning at the same time. Keep in mind that one end of the turnbuckle has normal threads and the other has reverse threads. Start the rod end straight and it will thread on straight.

**Step H-5**

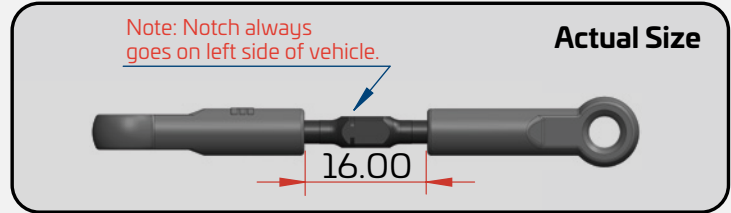
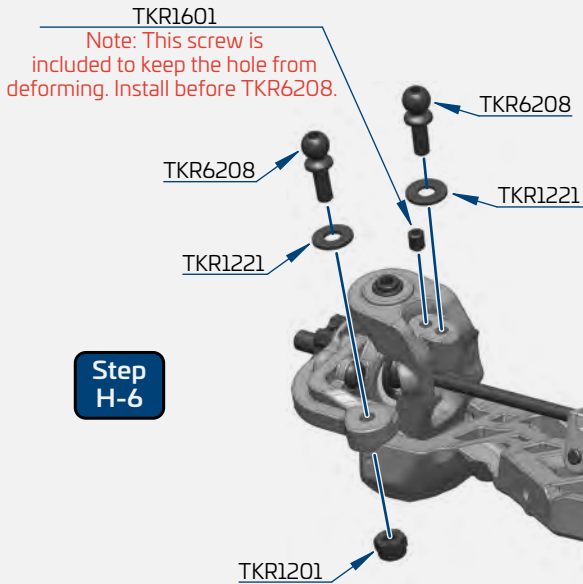

**Step H-6**

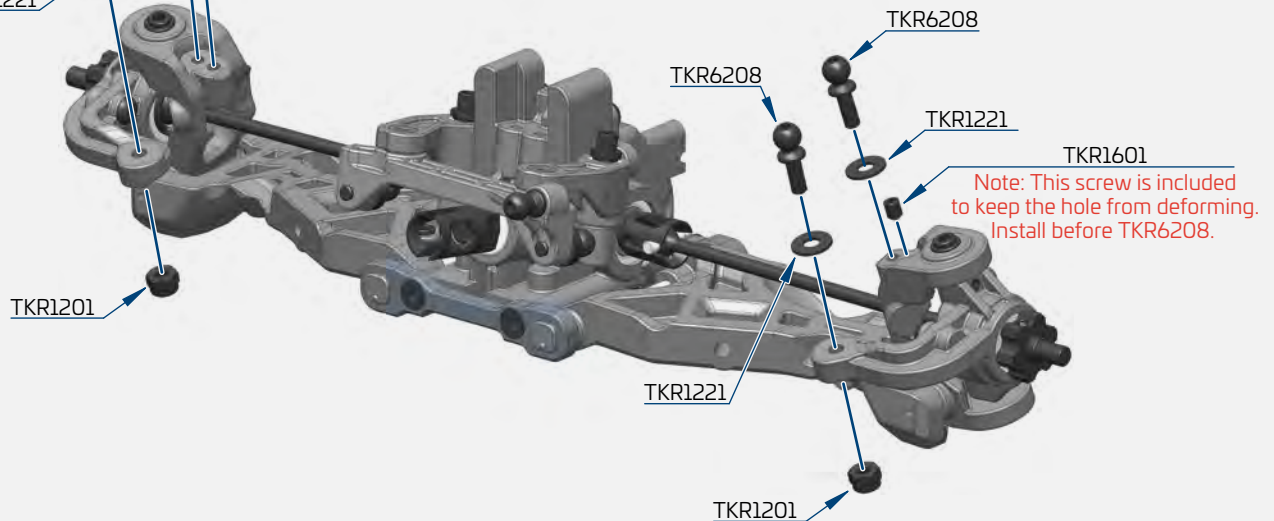

**Step H-7**

 x2  
TKR1201  
M3 Lock Nut Black

 x4  
TKR1221  
M3x8mm Washer

 x2  
TKR1601  
M3x4mm Set Screw

 x4  
TKR6208  
M3x8mm Ball Stud

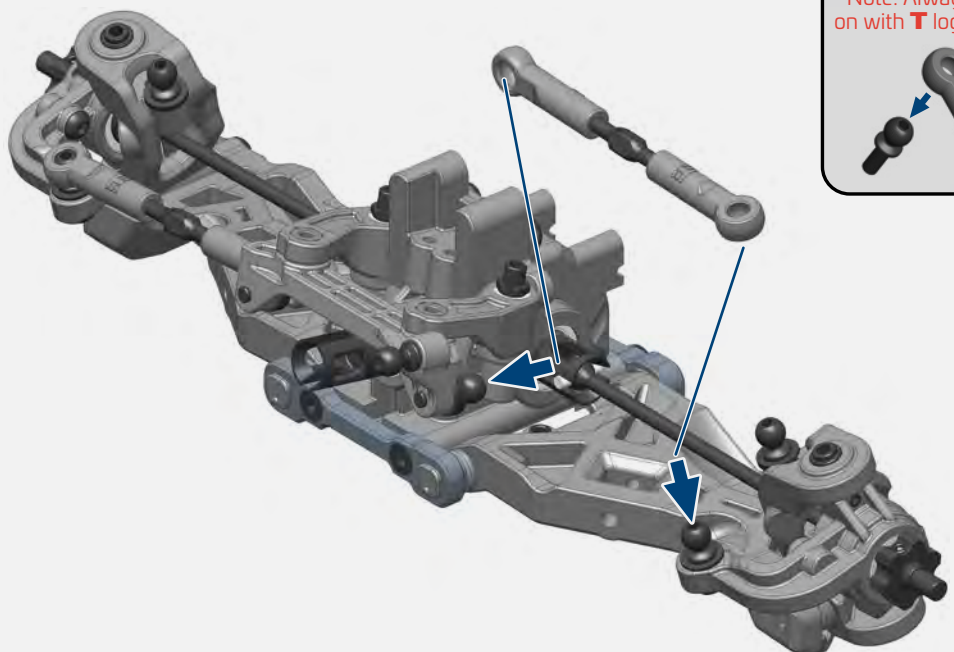

# Bag H

## Front Camber Links

**Build Tip:** Use some grease or Chapstick on the threads to help prevent "pop-off" when adjustments are being made.

**Build Note:** Hold the turnbuckle stationary with pliers and push the rod end hard onto the turnbuckle while turning at the same time. Keep in mind that one end of the turnbuckle has normal threads and the other has reverse threads. Start the rod end straight and it will thread on straight.

**Step H-8**

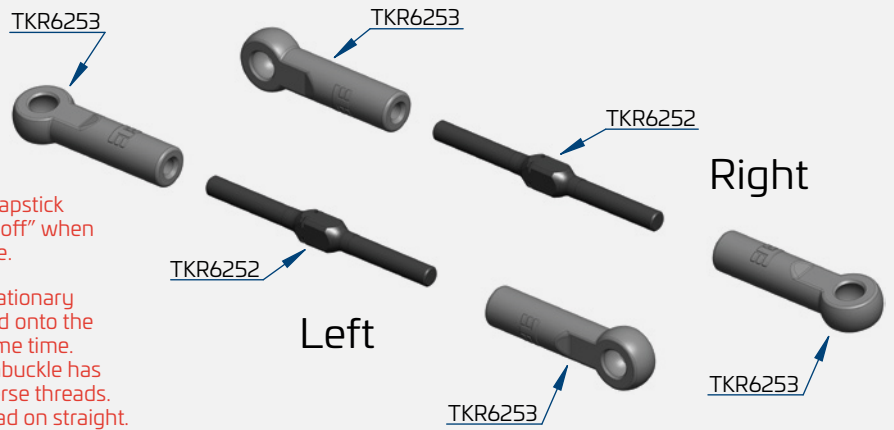

**Step H-9**

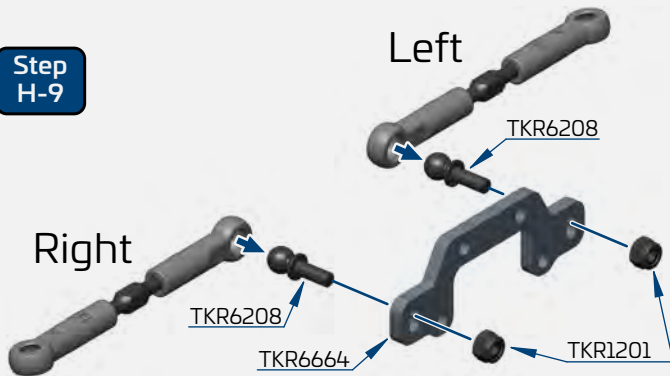

**Note:** Notch always goes on left side of vehicle.

**Actual Size**

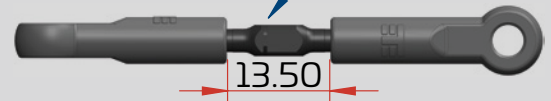

**Note:** Always press on with **T** logo visible.



**Step H-10**

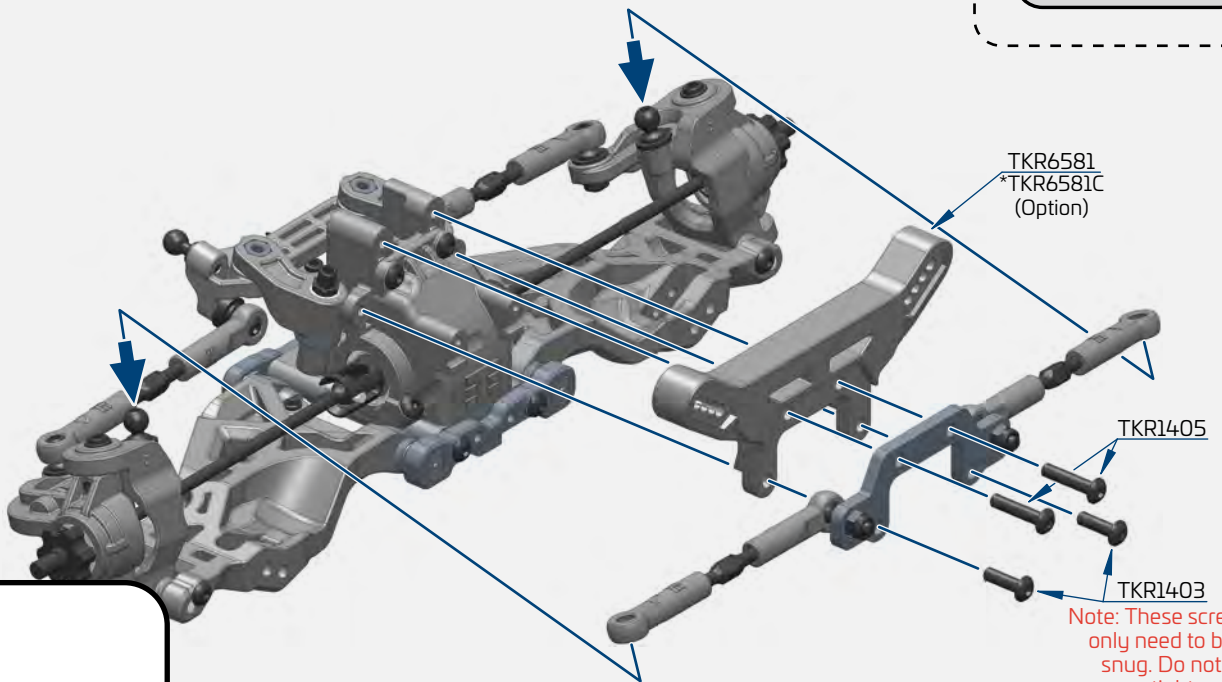

TKR6581  
\*TKR6581C (Option)

TKR1405

TKR1403

**Note:** These screws only need to be snug. Do not over-tighten.

x2  
TKR1201  
M3 Lock Nut Black

x2  
TKR1403  
M3x10mm Button Head Screw

x2  
TKR1405  
M3x14mm Button Head Screw

x2  
TKR6208  
M3x8mm Ball Stud

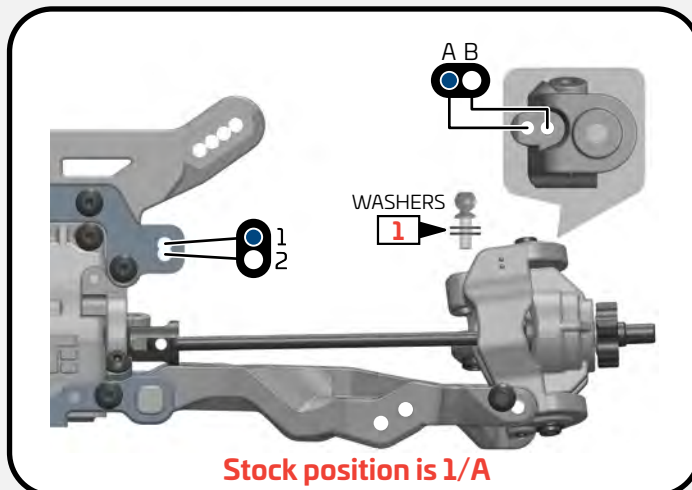

**Stock position is 1/A**

# Bag I

## Front/Center Assembly

Step  
I-1

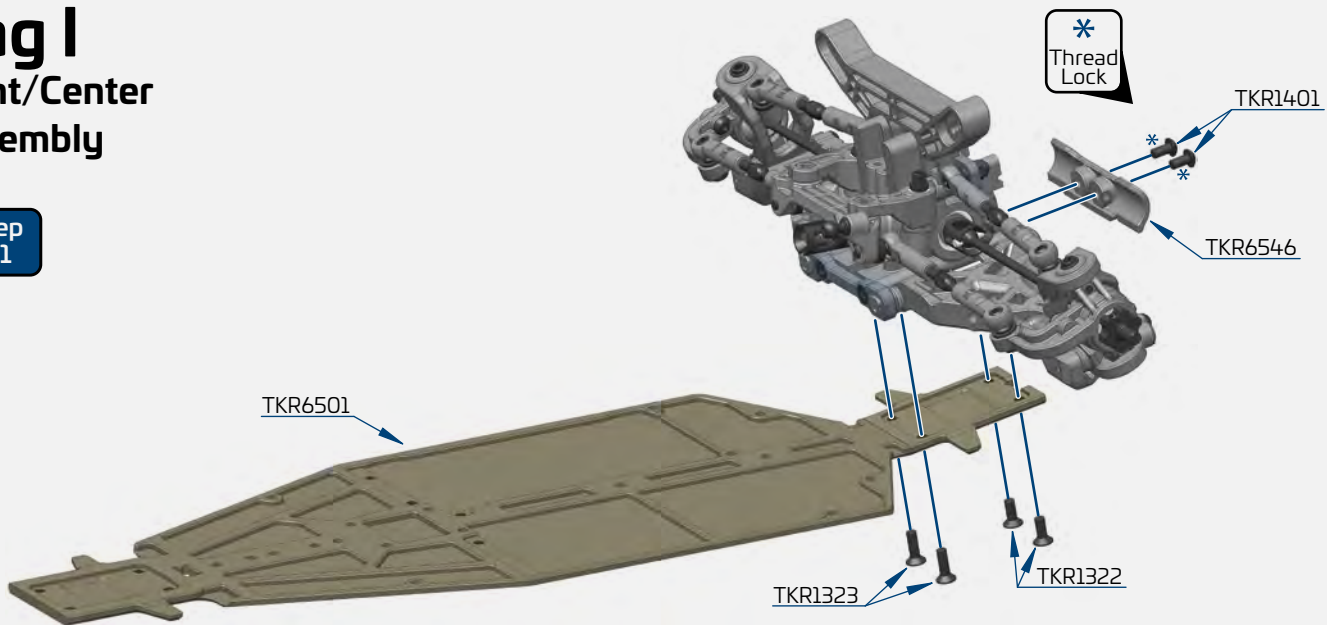

Step  
I-2

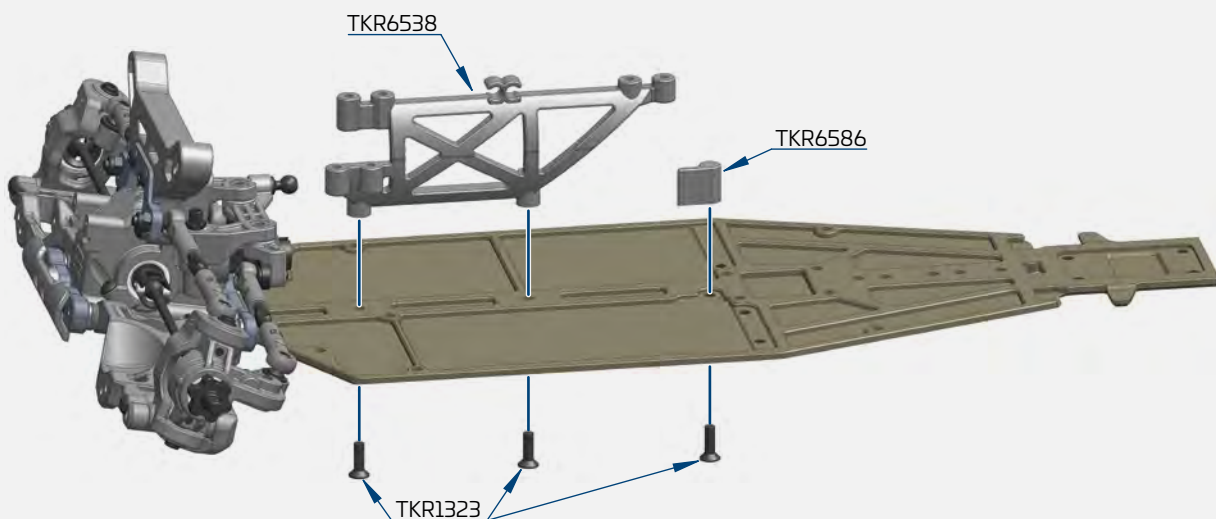

Step  
I-3

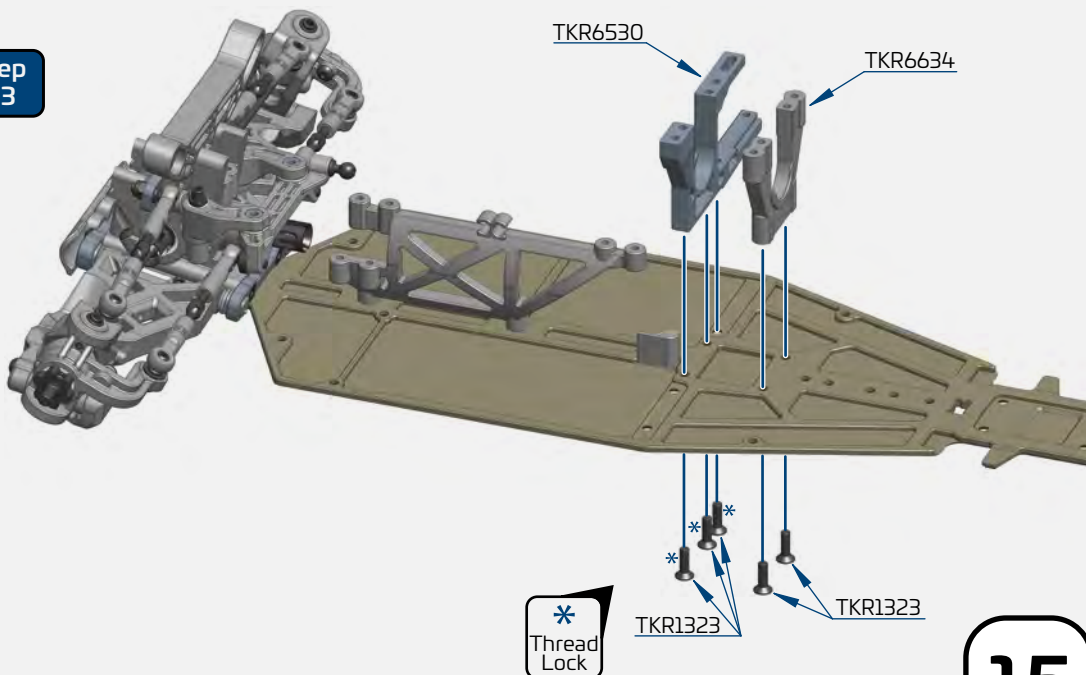

x2  
TKR1322  
M3x8mm Flat Head Screw

x10  
TKR1323  
M3x10mm Flat Head Screw

x2  
TKR1401  
M3x6mm Button Head Screw

\*  
Thread  
Lock

# Bag I

## Center/Rear Assembly

Step I-4

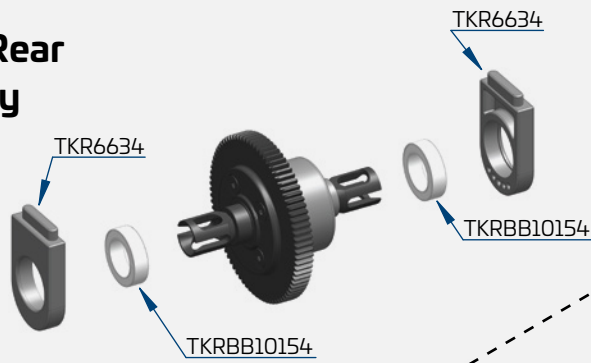

\* Thread Lock

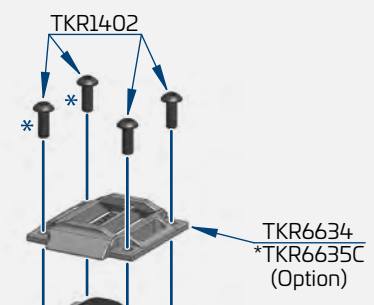

Step I-5

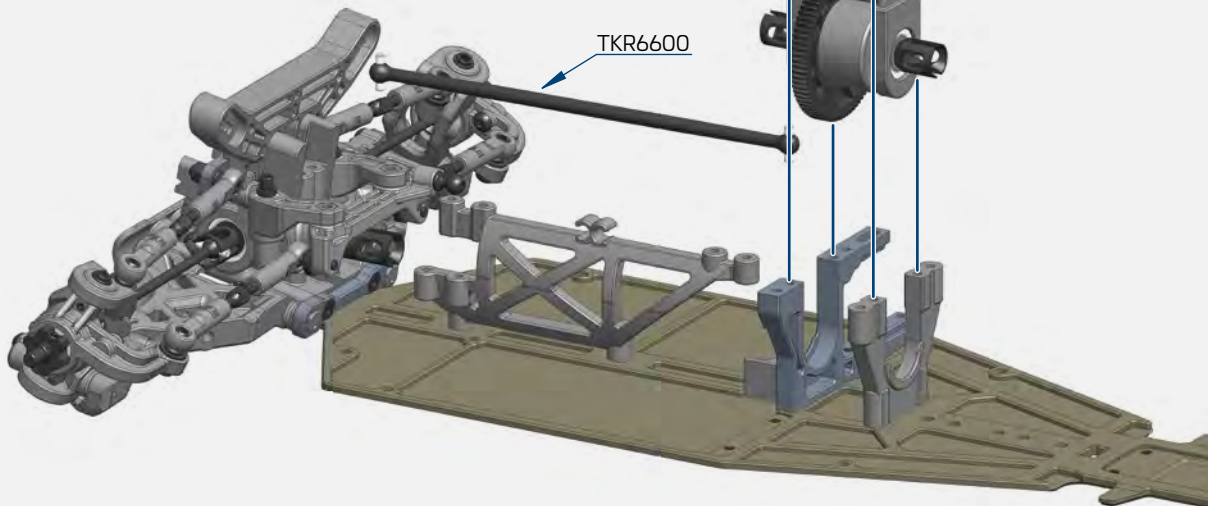

Step I-6

Note: Refer to page 25 when using the optional bulkhead risers.

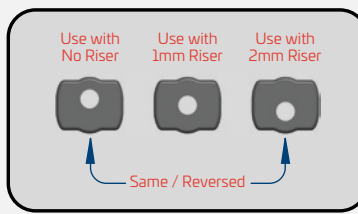

Note: Use both rear braces for the least chassis flex. Use just the long rear for less flex and short rear for the most flex. More flex is best suited for bumpy tracks.

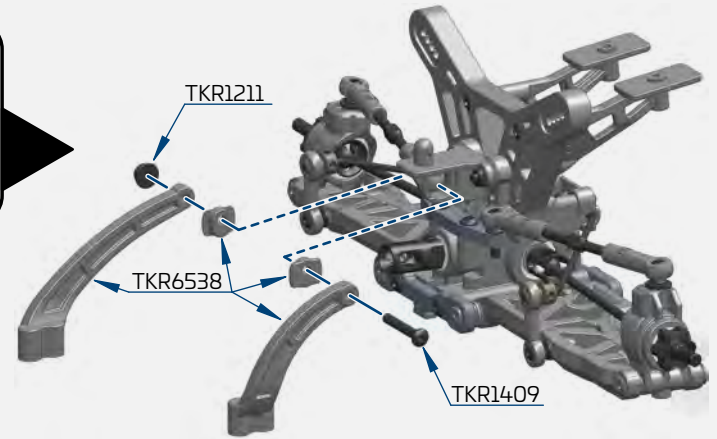

x1  
TKR1211  
M3 Lock Nut Flange Black

x8  
TKR1323  
M3x10mm Flat Head Screw

x4  
TKR1402  
M3x8mm Button Head Screw

x1  
TKR1409  
M3x20mm Button Head Screw

x2  
TKRBB101504  
Ball Bearing(10x15x4mm)

Step I-7

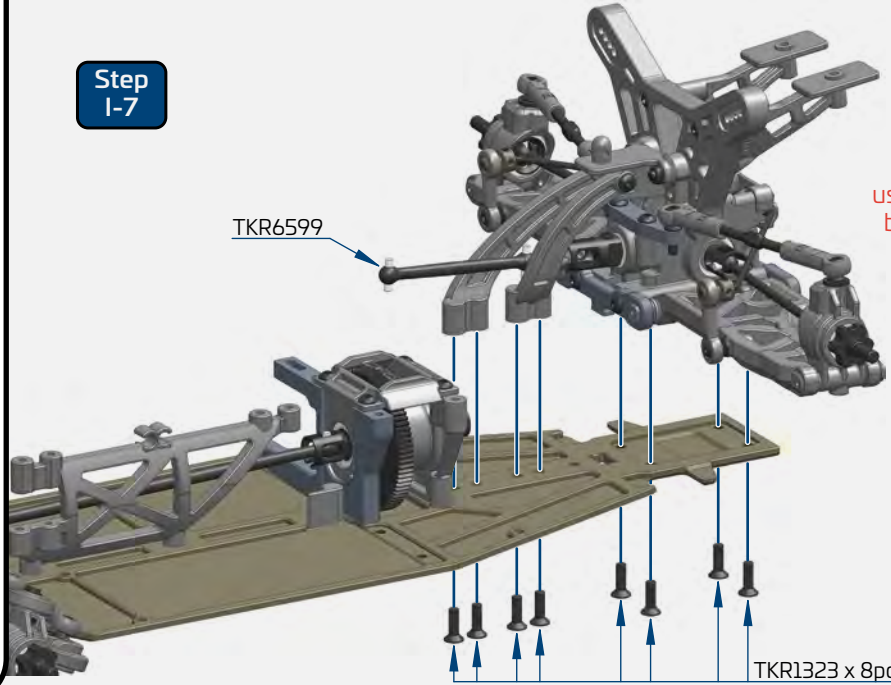

Note: Refer to page 25 when using the optional bulkhead risers.

TKR1323 x 8pcs



# Bag J Front Shock Assembly

## Step J-1

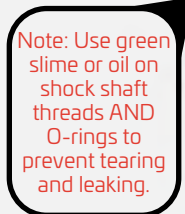

## Step J-3

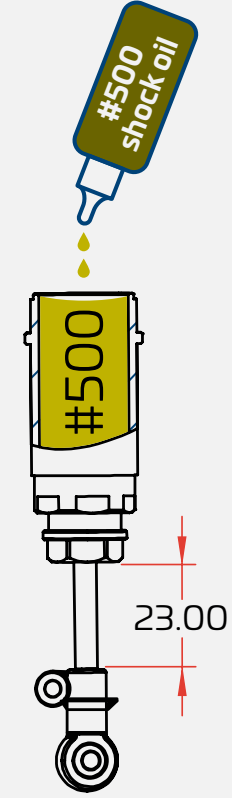

Refer to filling instructions on page 19 during this step.

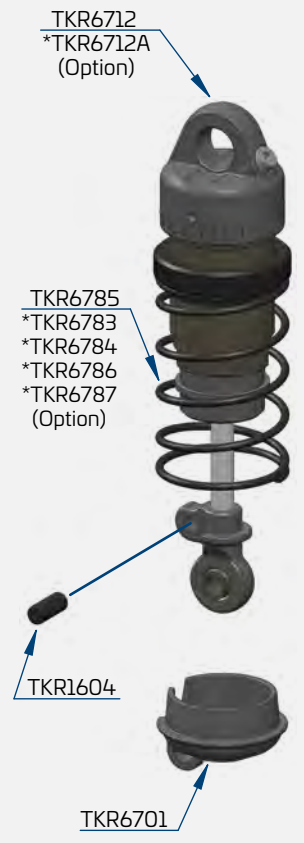

Note: Screw rod end on until distance measures 23mm at full extension.

## Step J-4

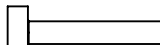
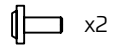
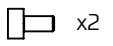

-  x4  
TKR1211  
M3 Lock Nut Flange Black
-  x2  
TKR1240  
M3x18mm Shock Mnt Screw
-  x2  
TKR1245  
M2x5mm Piston Screw
-  x2  
TKR1248  
M2x4mm Emulsion Screw
-  x2  
TKR1604  
M3x8mm Set Screw

## Step J-5

Note: Slot in spring perch should face outside of car.

TKR1240  
Note: Black screw is RH threaded. It goes on the left side of the car.

Silver screw is LH threaded. It goes on the right side of the car.

- Stock shock position is outside hole on the arm and 2nd from inside hole on the tower (2/B)
- Stock front ride height is 18mm
- Shock length (droop) is 78mm

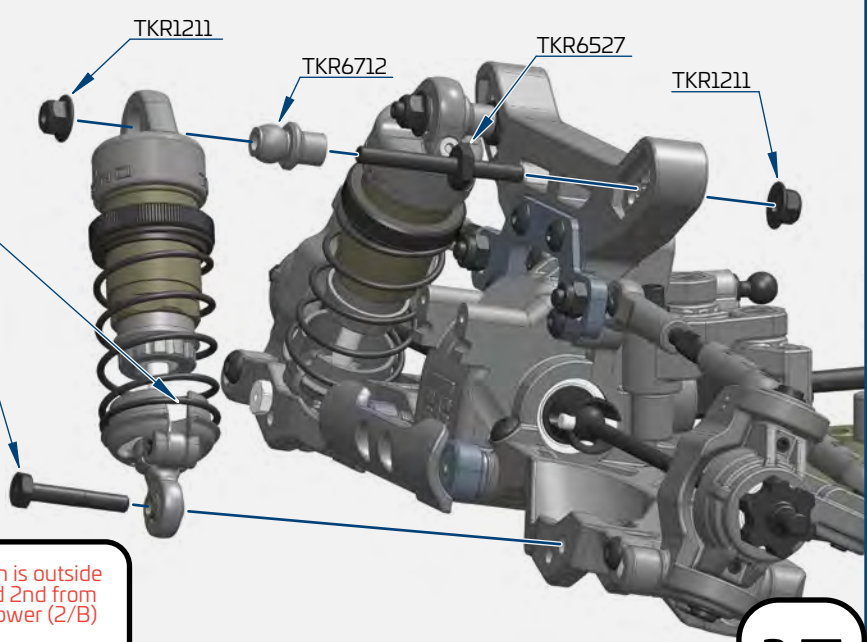

# Bag K Rear Shock Assembly

## Step K-1

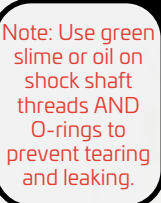

## Step K-2



## Step K-3

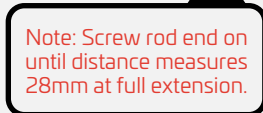
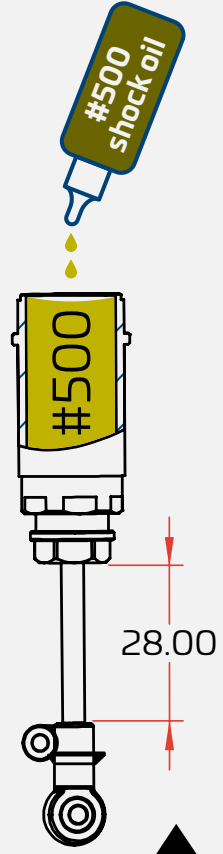
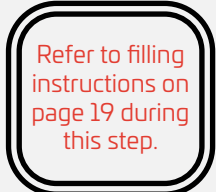

## Step K-4

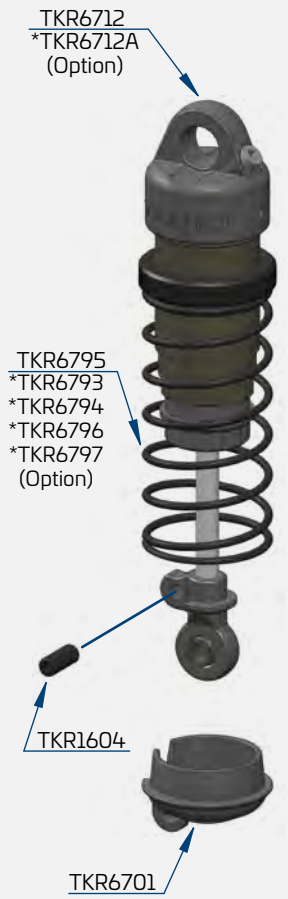

x4  
TKR1211  
M3 Lock Nut Flange Black

x2  
TKR1240  
M3x18mm Shock Mnt Screw

x2  
TKR1245  
M2x5mm Piston Screw

x2  
TKR1248  
M2x4mm Emulsion Screw

x2  
TKR1604  
M3x8mm Set Screw

## Step K-5

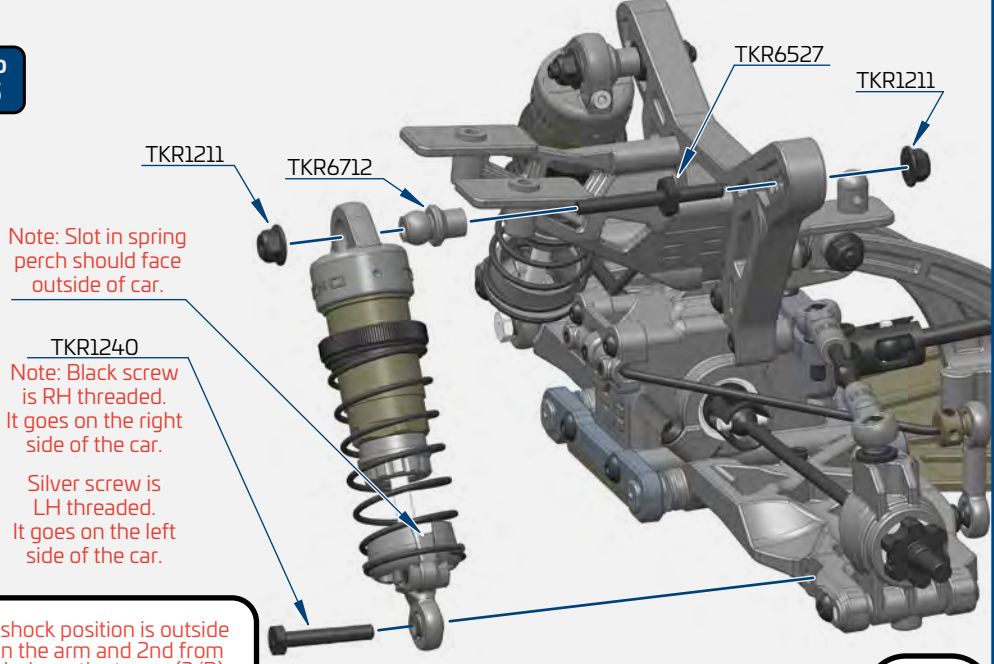

Note: Slot in spring perch should face outside of car.

Note: Black screw is RH threaded. It goes on the right side of the car.  
Silver screw is LH threaded. It goes on the left side of the car.

- Stock shock position is outside on the arm and 2nd from inside hole on the tower (2/B)
- Stock rear ride height is 21mm
- Shock length (droop) is 88mm

# Shock Filling Instructions

## For both front and rear shocks

We've found it's easiest to complete steps 1 & 2 on each shock before moving on to step 3. By the time you've finished step 2 on the last shock, the first one will be ready for step 3.

**Step 1.** Start by drilling out the emulsion hole. Use a 1/16th (or 1.6mm) drill bit to drill all the way through and clear any flashing created by this. Insert the four larger o-rings into the emulsion caps and set aside. Install the small o-rings onto the small emulsion screws by placing the o-rings on a pit mat or towel and pressing the screws into the o-rings (add 1 small drop of oil onto the seal to help make the screw slide in easier).

**Step 2.** Fill shock with oil all the way to the top and pump the shock shaft up and down 3-5 times.

**Step 3.** Screw on the cap all the way tight (shock tool TKR1115 is helpful for holding the shock body). Be careful to not cross-thread the caps. Start by turning in the opposite direction before tightening.

**Step 4.** With the shock at about a 45° angle, push and hold the shock shaft to the top of the stroke and insert the prepared emulsion screw/seal. Oil should leak out during this process. If it does not, add more oil. Tighten the screw until snug (do not over-tighten). Wipe off excess oil before moving on to step 5.

**Step 5.** Pump the shock shaft up and down about 20 times vigorously. This emulsifies the oil.

**Step 6.** With the shock shaft fully extended, remove the emulsion screw from the cap to do the final bleed.

**Step 7.** With the shock at about a 45° angle, push and hold the shock shaft to the top and insert the prepared emulsion screw/seal again. Oil will leak out during this process. Finish by tightening the screw until snug (do not over-tighten).

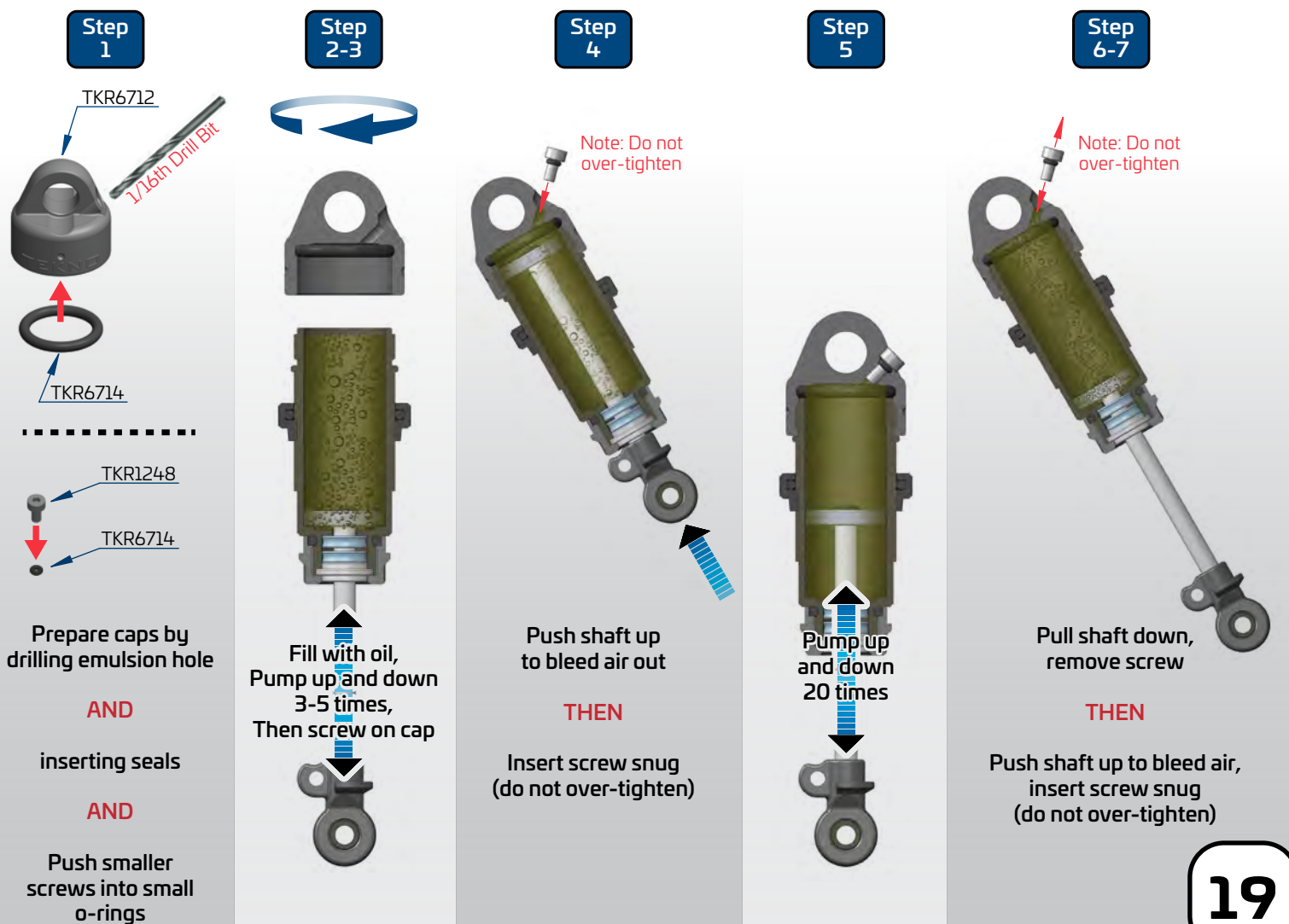

# Bag L

## Final Assembly

**Steering servo (not included)**  
 Note: We recommend using a low profile servo with at least 150 oz/in torque and metal gears. Running less than our recommended rating will increase the chance of premature servo failure.

### Step L-1

For Low Profile servo installation, see page 24.

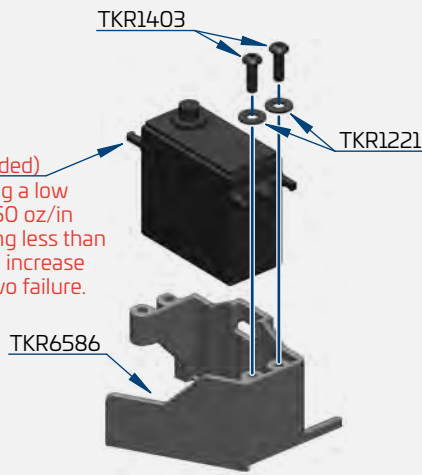

### Step L-2

Motor (not included)

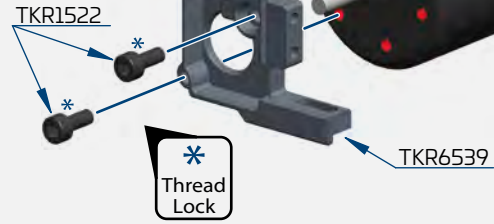

### Step L-3

For Low Profile servo installation, see page 24.

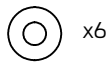
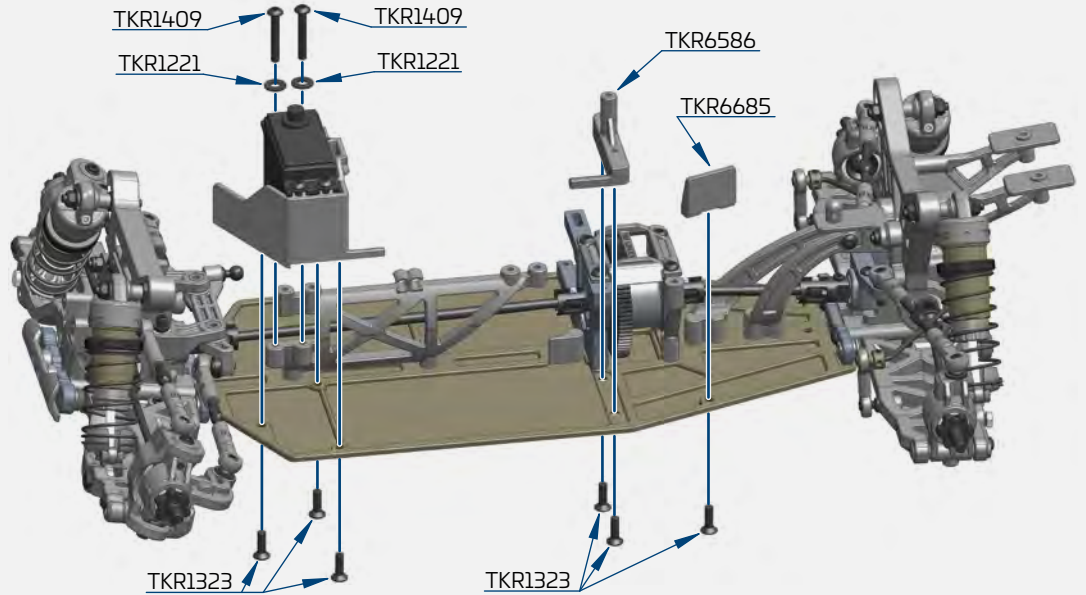

x6  
 TKR1221  
 M3X8mm Washer

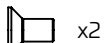

x2  
 TKR1321  
 M3x6mm Flat Head Screw

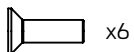

x6  
 TKR1323  
 M3x10mm Flat Head Screw

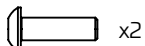

x2  
 TKR1403  
 M3x10mm Button Head Screw

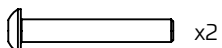

x2  
 TKR1409  
 M3x20mm Button Head Screw



x2  
 TKR1522  
 M3x8mm Cap Head Screw

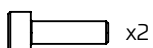

x2  
 TKR1523  
 M3x10mm Cap Head Screw

### Step L-4

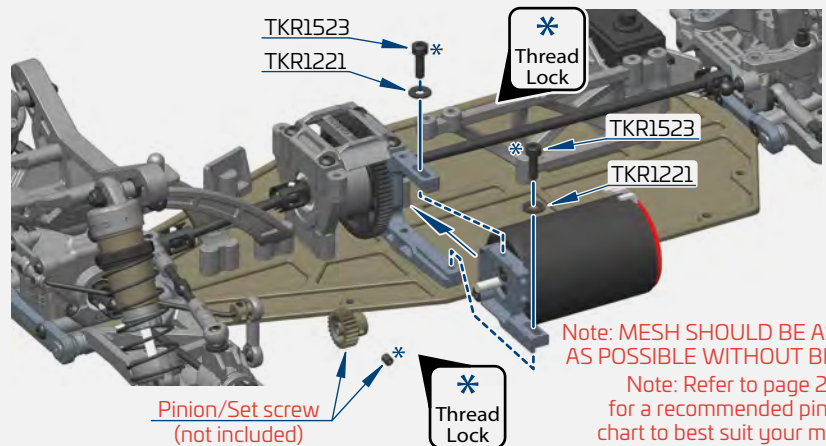

Note: MESH SHOULD BE AS TIGHT AS POSSIBLE WITHOUT BINDING.  
 Note: Refer to page 27 for a recommended pinion chart to best suit your motor.

### Step L-5

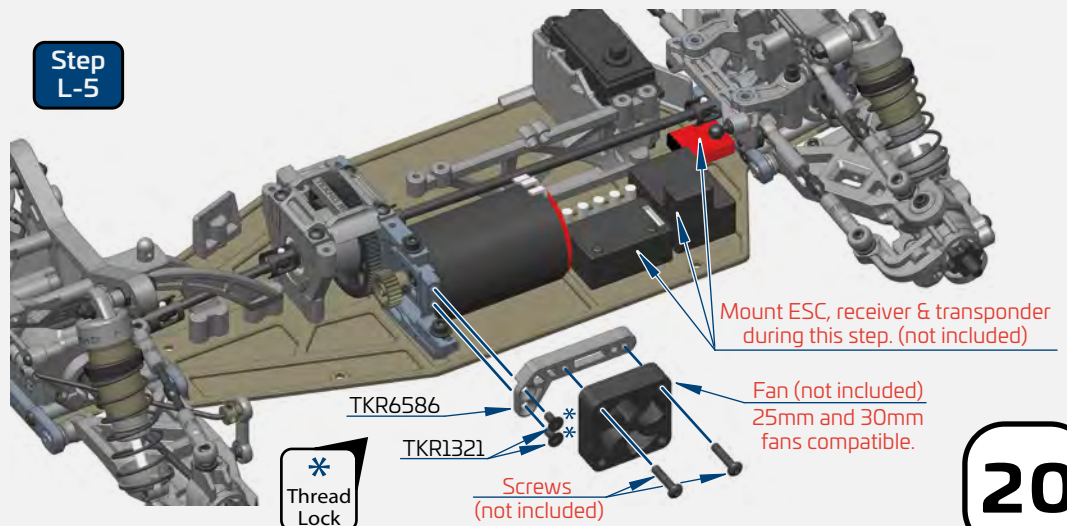

# Bag L

## Final Assembly

Step L-6



Actual Size

3.00

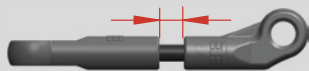

Step L-7

Note: Servo horn orientation.

TKR6526  
\*TKR6563A  
(Option)

TKR6207

Note: Rod end orientation.

Note: Always press on with **T** logo visible.

Step L-8

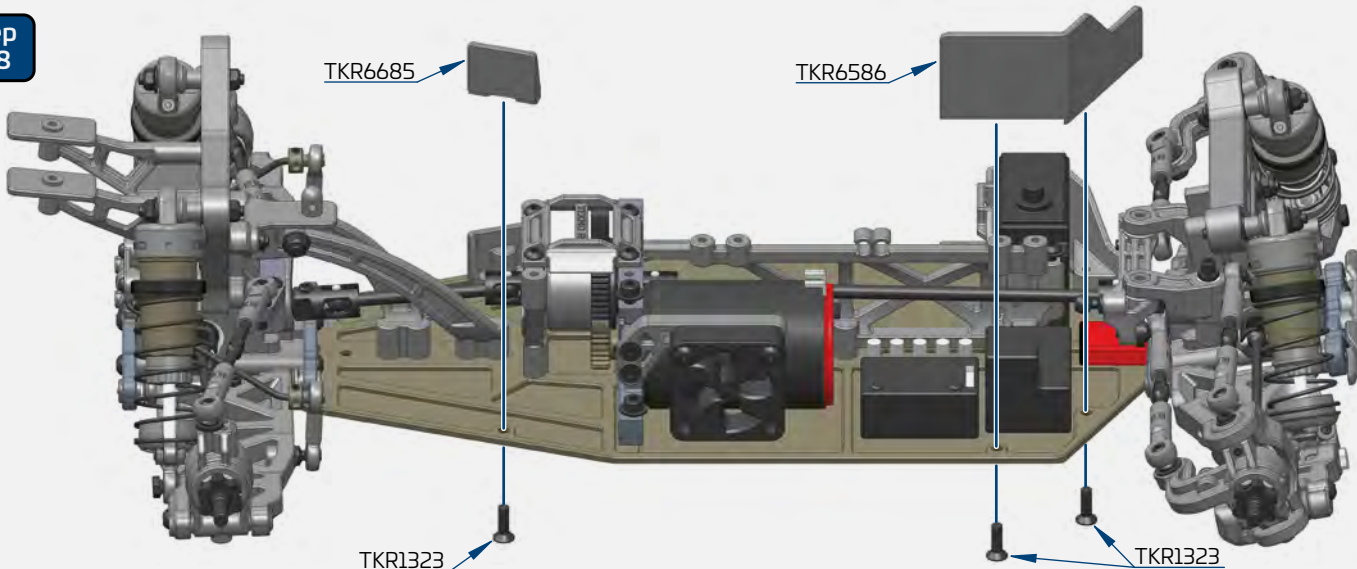

Step L-9

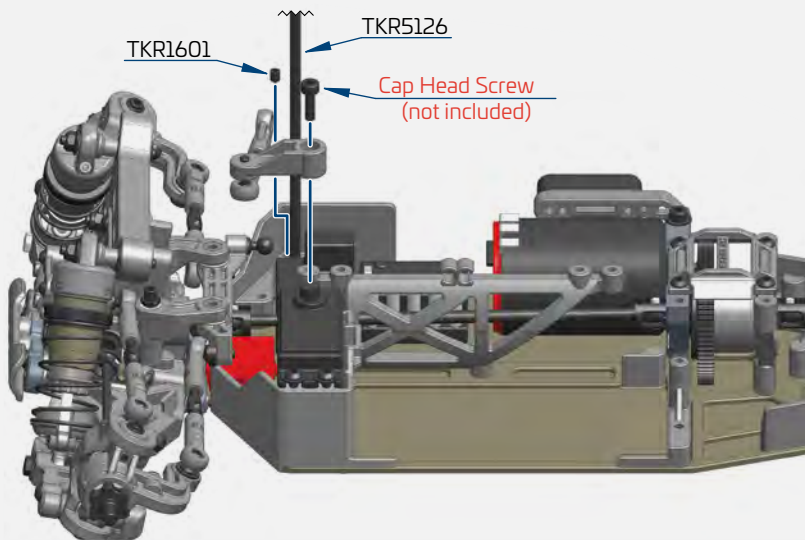

x3  
TKR1323  
M3x10mm Flat Head Screw

x1  
TKR1601  
M3x4mm Set Screw

x1  
TKR5230  
M3x18 Threaded Rod

x1  
TKR6207  
M3x6mm Ball Stud

### SERVO HORN ALIGNMENT

Step L-10

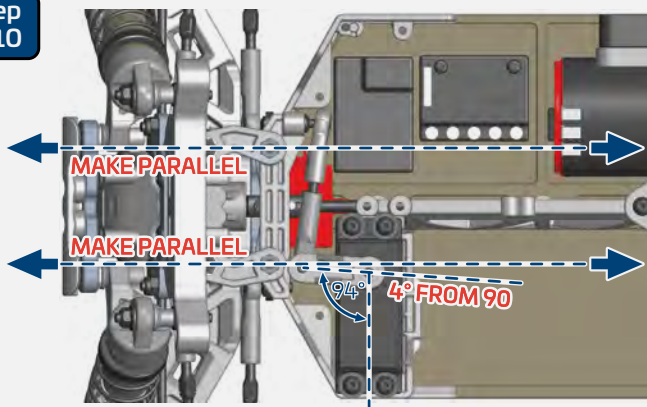

Note: Servo horn should be positioned after trim and sub-trim have been zero'd out. It should be positioned about 4 degrees off parallel from the steering bellcranks.

Steering bellcranks should be perfectly parallel from front to rear of the chassis.

# Bag M

## Final Assembly

Step  
M-1

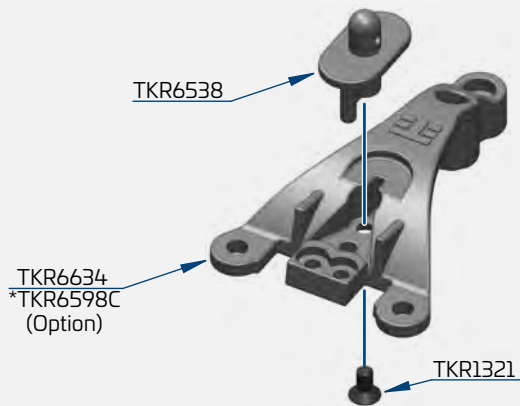

TKR6634  
\*TKR6598C  
(Option)

TKR1321

Step  
M-2

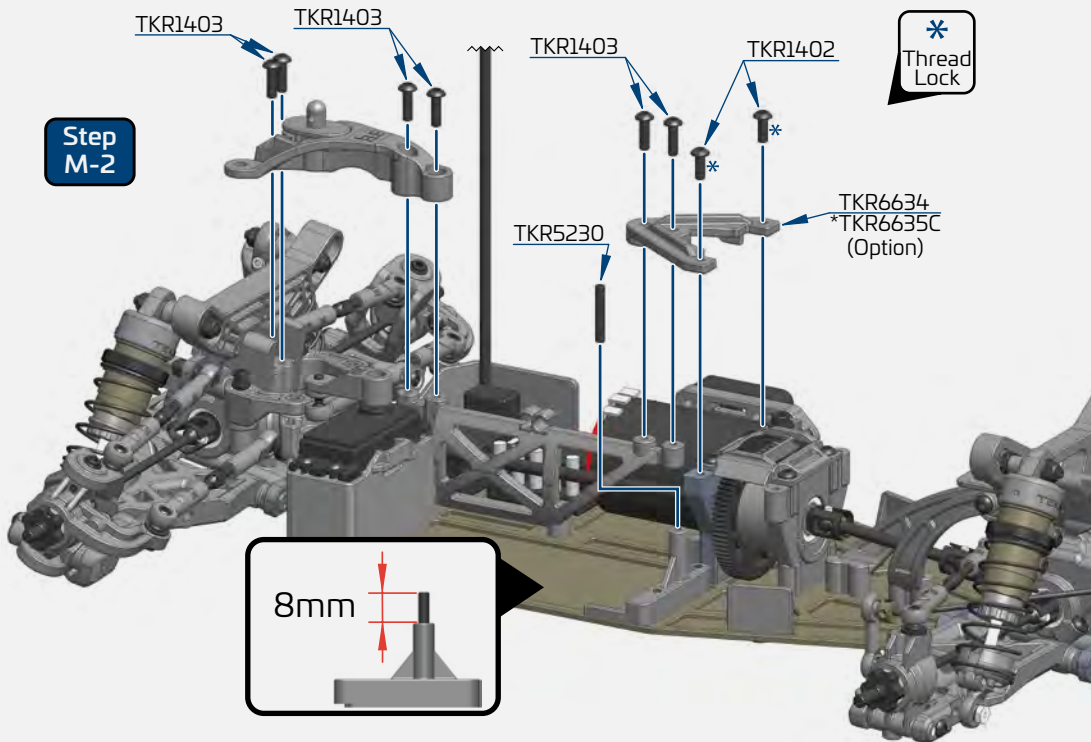

\*  
Thread  
Lock

x1  
TKR1321  
M3x6mm Flat Head Screw

x2  
TKR1402  
M3x8mm Button Head Screw

x6  
TKR1403  
M3x10mm Button Head Screw

x1  
TKR5230  
M3x18 Threaded Rod

8mm

# Bag N

## Wing

Step  
N-1

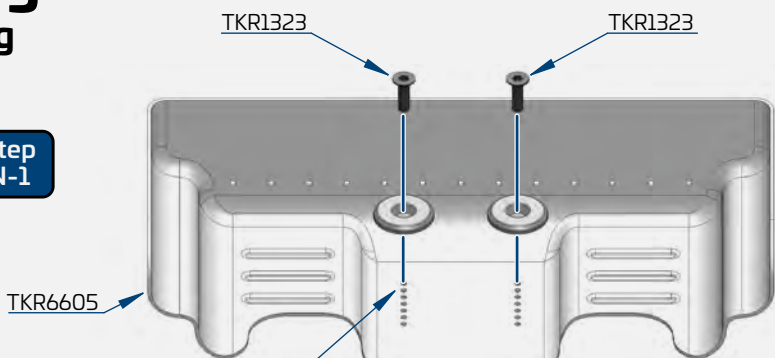

Note: Stock hole position is in the rear of the wing. Move the wing forward to create less rear downforce during high speed driving.

### DOWNFORCE OPTIONS

Shim/Direction	Shim	Angle	Total Wing Angle
3°	▲	3°	9°
1.5°	▲	1.5°	7.5°
0°	▲	0°	6°
1.5°	▼	1.5°	4.5°
3°	▼	3°	3°

Note: Stock downforce is 6°

Note: More downforce will give more rear traction everywhere, will jump more nose up, have less steering into a turn, and have slightly less top speed. Less downforce will have less rear traction everywhere, will jump more level or nose down, have more steering into a turn, and have a slightly higher top speed.

x2  
TKR1323  
M3x10mm Flat Head Screw

# Bag N

## Body/Tires

Step N-2

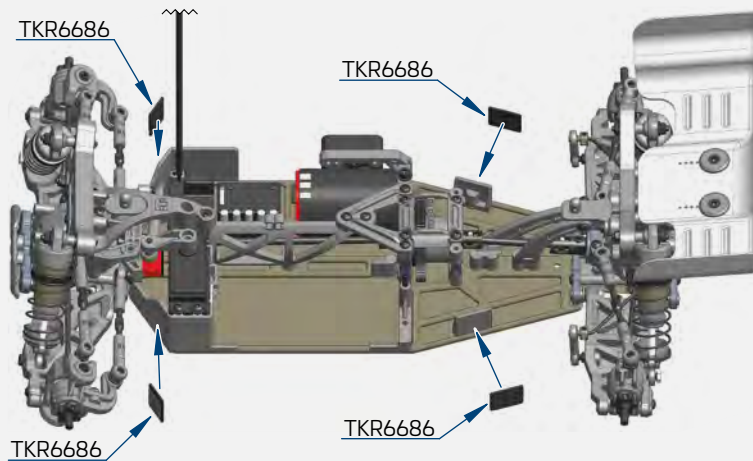

Step N-3

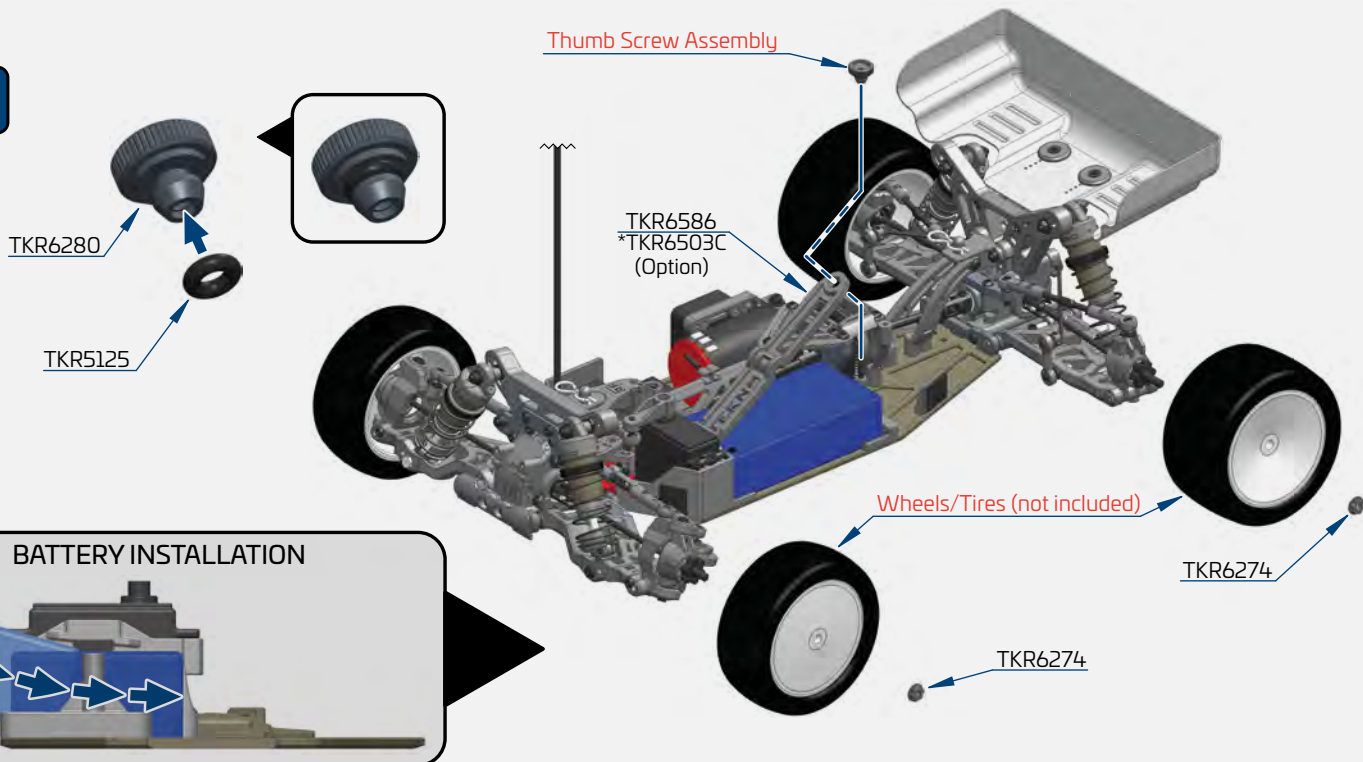

Step N-4

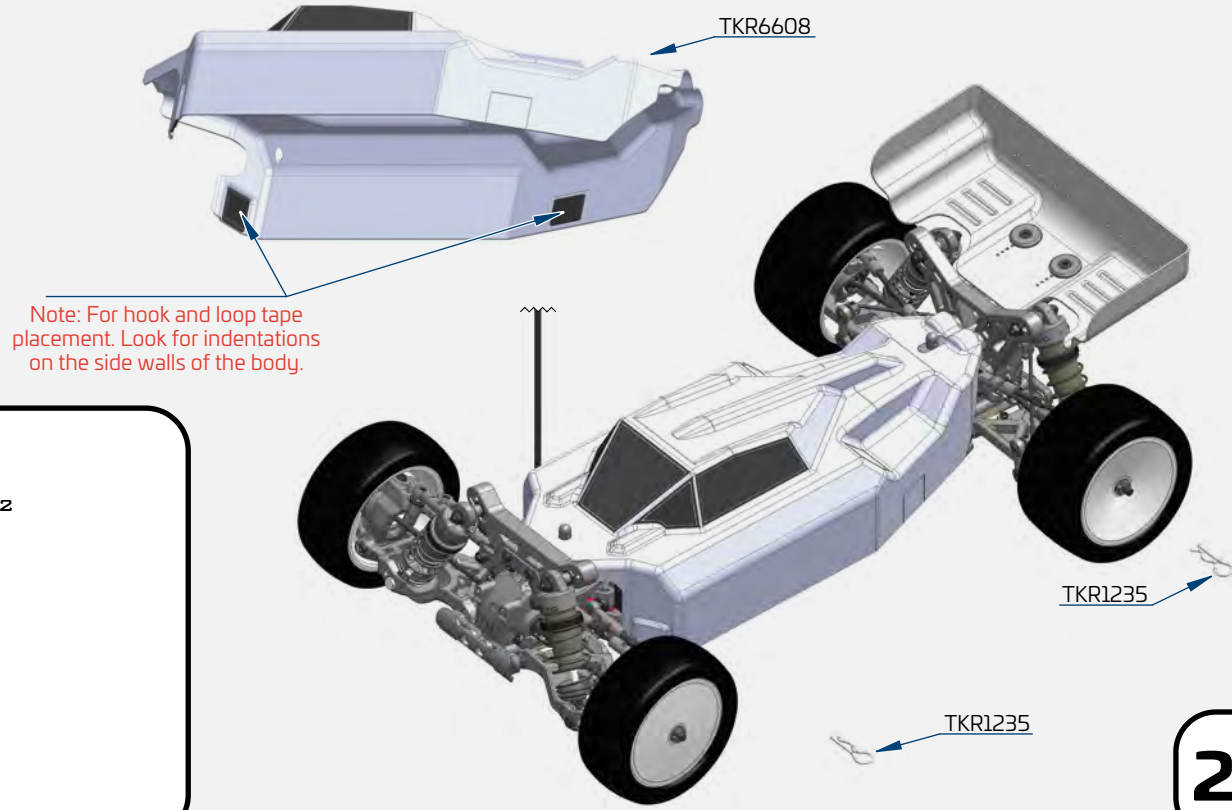

x2

TKR1235  
BODY CLIP

x4

TKR6274  
WHEEL NUT

# Bag 0

## Optional Low Profile Servo Mounting

Step  
0-1

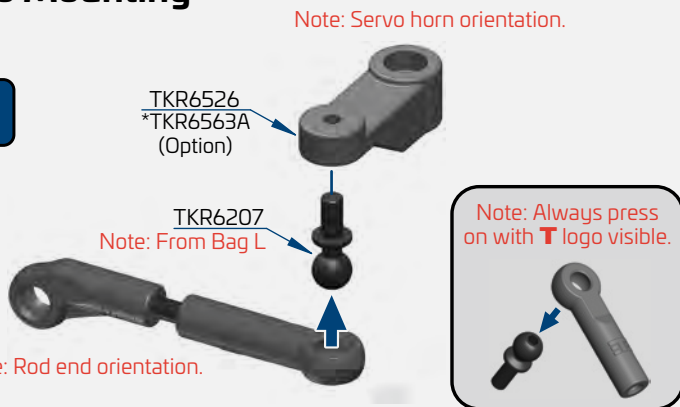

Step  
0-2

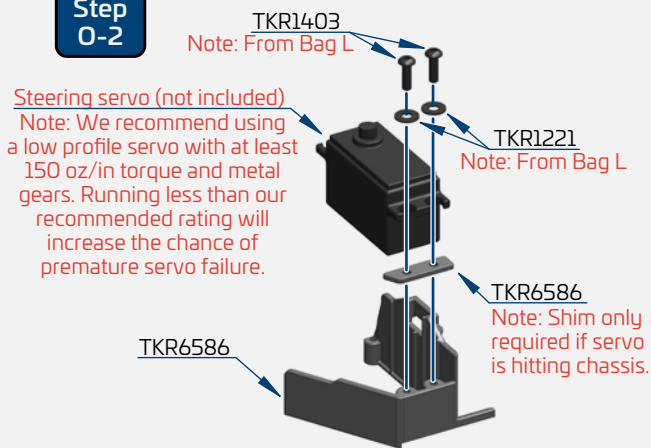

Step  
0-3

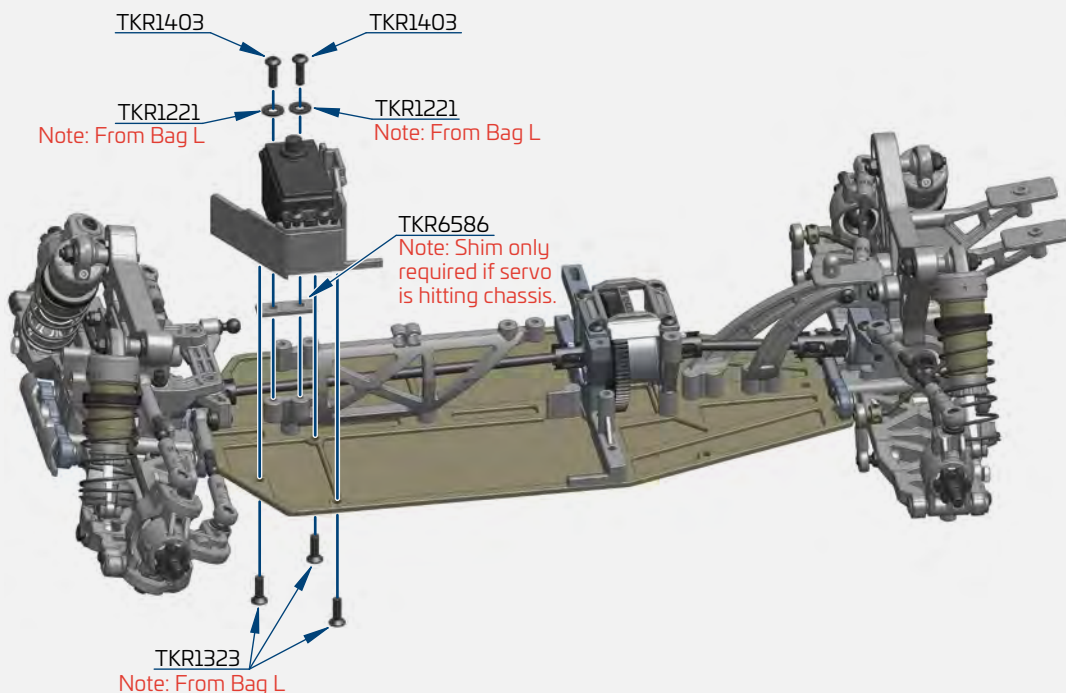

Step  
0-4

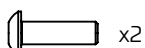
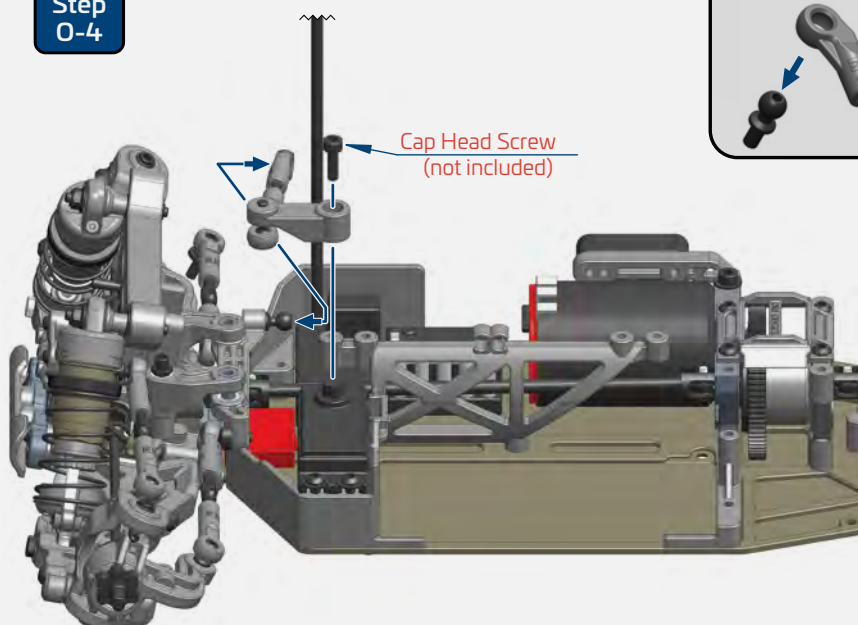

TKR1403  
M3x10mm Button Head Screw



# Optional Diff Shims/ Front Sway Bar

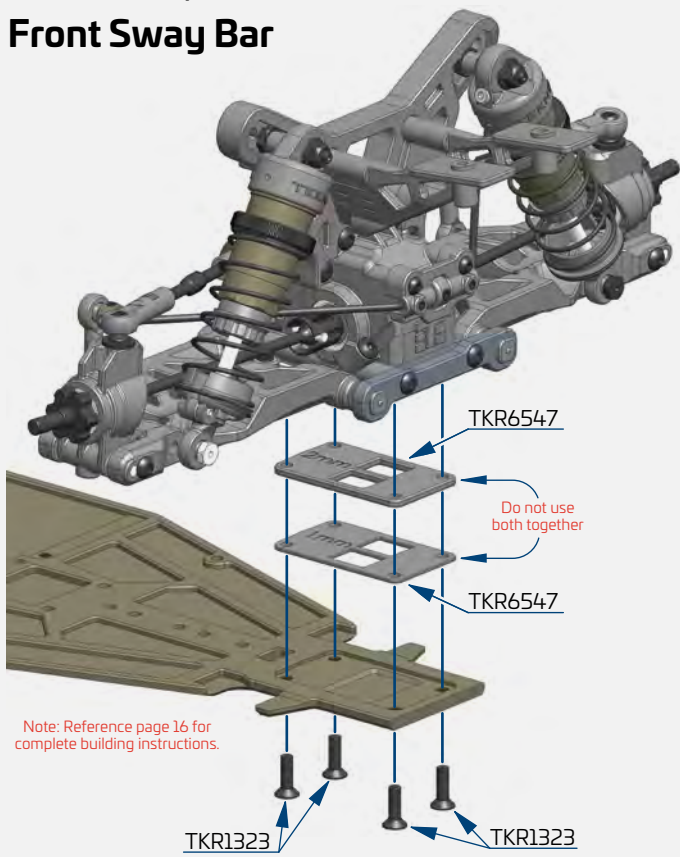

## Diff Shim Options

Option A: NO RISER (rough track)	Option B: 1mm RISER (most tuning options)	Option C: 2mm RISER (smooth track)
Stock C and D Blocks	Stock C and D Blocks (Higher Roll Center)	
Stock Camber Plate	Option Riser C and D Blocks (Lower Roll Center)	Option Riser C and D Blocks (Lower Roll Center)
Stock Tower	Option Carbon Tower (Adds 2mm More Droop) (TKR6582XC)	Option Carbon Tower (Adds 1mm More Droop) (TKR6582XC)
Option Carbon Tower (Adds 1mm More Droop) (TKR6582XC)	Option Carbon Tower (Adds 2mm More Droop) (TKR6582XC)	Option Carbon Tower (Stock Droop) (TKR6582XC)
2mm Riser Camber Plate (TKR665A)		

Note: Optional shock tower and riser C and D blocks are not included in the kit.

### Step 1

TKR6623 - Front Sway Bar Kit (not included)

Includes:  
1.0mm  
1.1mm  
1.2mm  
1.3mm  
1.4mm

TKR1601  
Note: Do not over-tighten.

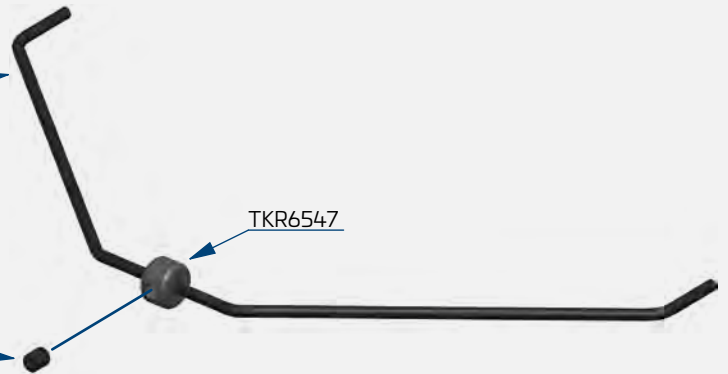

### Step 2

x2  
TKR1409  
M3x20mm Button Head Screw

x2  
TKR1463  
M2.5x6mm Button Head Screw

x3  
TKR1601  
M3x4mm Set Screw

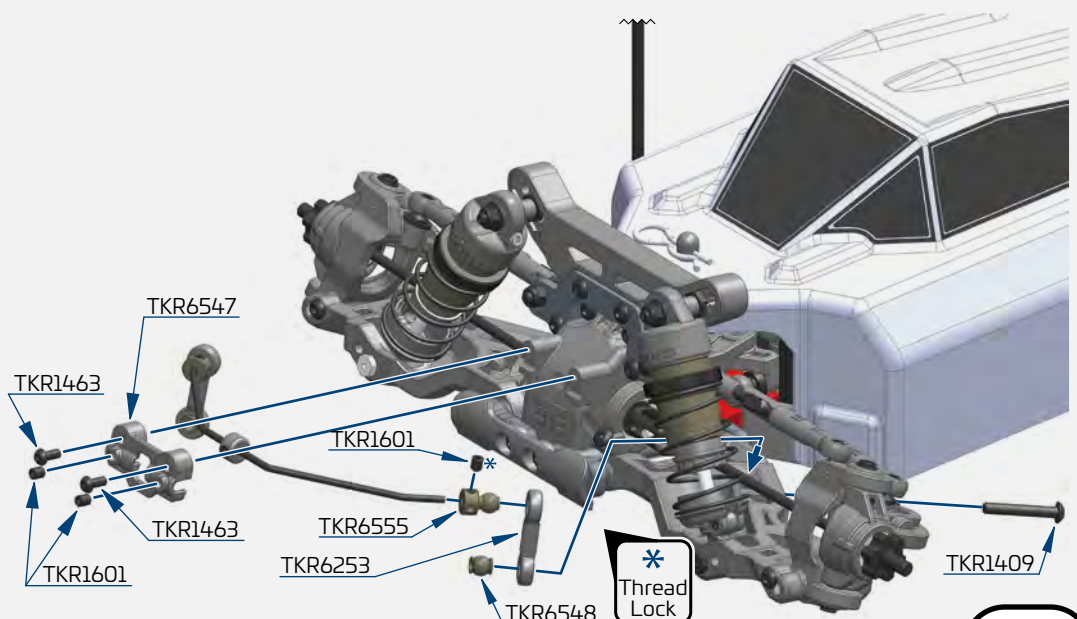

# Set Up Information

The purpose of making adjustments is to make the car go faster around the track, or to make it more controllable, or both if possible. A car that's easier to drive should produce lower, more consistent lap times. It will also inspire more confidence in the driver, which is always good when nerves start getting the best of you.

Before you start thinking about changing your car's setup, consider these two things: First, is the car in perfect working order? Be sure that all of the suspension components operate freely without excessive play, and that the car isn't tweaked. Binding and worn out parts will result in poor performance and inconsistent handling. Second, always consider tires before making other adjustments. Time spent trying to get the vehicle to work with the wrong tires mounted will be wasted time. Without the right tires, even a great setup won't be a winning setup.

## Ride Height

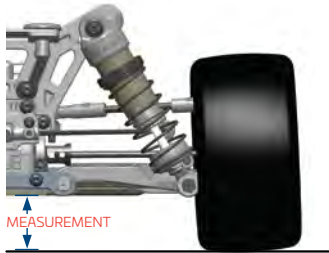

Ride height is the distance from the bottom of the chassis to the running surface. Ride height should only be checked and adjusted with your vehicle ready to run (i.e. with battery installed/body on). Ride height is the first adjustment to be made and should be set with a ride height measurement tool. Measurements should be taken from the flat parts of the chassis, front and rear. Be sure to measure the front ride height at a point before the kick up in the chassis starts. To measure ride height, first make sure the suspension is completely free, then simultaneously compress the front and rear all the way down and let the vehicle settle. Take your measurement from that position. Use the shock spring adjustment collars to raise or lower the ride height to your desired setting. 18 - 20mm front and 21 - 23mm rear is a good starting point.

## Front Toe

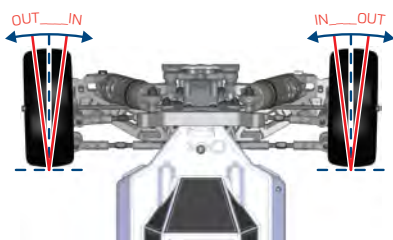

Front toe is used to describe the angle in which the front wheels point when looking down at them from the top of a vehicle. You will always use some amount of toe out. Toe-out will affect how your vehicle enters and exits corners. More toe out will result in more off-power steering and less on-power steering and less toe out will have the opposite results. To set your front toe, have your vehicle at ride height (see above) and adjust the steering links until desired angle is achieved. Please note that a large adjustment of front toe will affect front camber and you may have to readjust the camber and then re-check front toe again. A good starting point is approximately 1-2 degrees of toe out.

## Camber

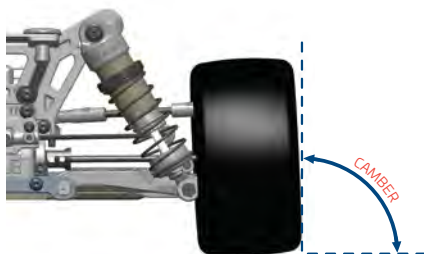

Static camber affects the car's side to side traction. More negative camber front and rear quickens rotation in corners. Less negative camber will make the vehicle easier to drive but you may give up some responsiveness (i.e. steering). To set your static camber have your vehicle at ride height (see above) and adjust the camber links until desired angle is achieved. Please note that a large adjustment of front camber will affect front toe and you may have to readjust the toe and then re-check front camber again. A good starting measurement for camber is 1-2 degrees in the front and 1.5-2.5 degrees in the rear.

## Ackermann Effect

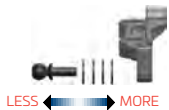

Think of Ackermann as active toe when the steering moves from left to right. More ackermann effect makes more toe out at full turn and produces more steering off-power. Less ackermann effect makes less toe out at full turn and produces more steering on-power. A good starting point is 4 washers behind the ball stud (2mm).

## Bumpsteer

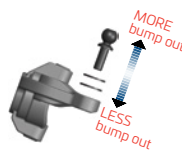

Think of bump steer as active toe when the suspension compresses or rebounds. To adjust bump steer you have to change the angle of the steering link. This is accomplished by adding or removing washers under the ball end on the steering spindles. Anytime you change camber link locations, front arm pills, front arm spacers, or Ackermann you will need to check and possibly adjust your bumpsteer. It's best to start with zero bumpsteer or slight bump out.

## Droop

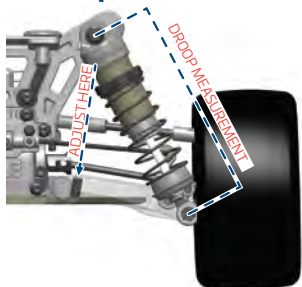

Droop is the measured amount of down travel in the suspension. It is measured from the shock mounting points while the vehicle is up on a stand allowing the arms to hang freely and is adjusted by turning the droop screw located in the suspension arms front/rear. This screw limits the suspension travel by providing a stopping point against the chassis. Left and right sides should always be equal, however the front and rear of the vehicle can have different values. Droop affects all aspects of chassis performance, including: braking, acceleration, jumping, traction and bump handling. A good starting droop measurement is 78mm front and 88mm rear.

# Set Up Information

(continued)

## Differentials



**Front:** Changing front diff oil affects overall steering response. Thinner can increase off-power steering but the vehicle may be twitchy and harder to drive. Thicker can increase on power steering and stability. We recommend 10k to 20k in the front diff.

**Center:** Changing center diff oil affects the front-to-rear drive balance. Thicker will reduce off-power steering and on-power rear traction but increases on-power steering and acceleration if traction is available. Thinner will increase off-power steering and on-power rear traction but reduce on-power steering and acceleration. We recommend 10k to 30k in the center diff.

**Rear:** Thinner rear diff oil increases off-power steering and reduces traction into a corner. It also reduces on-power steering and increases traction out of a corner. Going too thin will make your vehicle inconsistent, however. Thicker rear oil will have opposite effects, and once again, going too thick will make the vehicle inconsistent. We recommend 5k to 10k in the rear diff.

## Wheelbase Adjustments

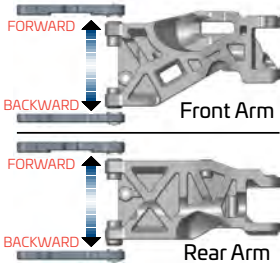

Changes to wheelbase can affect the overall handling of your vehicle, since it adjusts the distribution of weight on the wheels as well as the angle of the driveshafts. Shortening the wheelbase at the rear will give you more steering into a turn and off power, less steering out of a turn and on power. Lengthening the wheelbase at the rear will yield the opposite results.

Shortening the wheelbase in the front will land jumps a little better and lengthening it will be better through small bumps. In general a longer wheelbase is better on open and/or bumpy tracks and a shorter wheelbase is better on tighter technical tracks.

## Springs

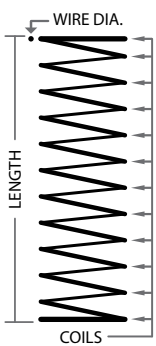

PART#/COLOR	F / R	WIRE DIA.	COILS	LENGTH	RATE
TKR6783	Front	1.3	9.5	45mm	2.95
TKR6784	Front	1.3	9.0	45mm	3.16
TKR6785	Front	1.3	8.5	45mm	3.41
TKR6786	Front	1.3	8.13	45mm	3.62
TKR6787	Front	1.3	7.75	45mm	3.85
TKR6793	Rear	1.2	9.38	53mm	2.20
TKR6794	Rear	1.2	8.75	53mm	2.41
TKR6795	Rear	1.2	8.25	53mm	2.60
TKR6796	Rear	1.2	7.75	53mm	2.82
TKR6797	Rear	1.2	7.38	53mm	3.02

Softer springs will increase traction through the turns by allowing more roll, slow down the responsiveness of the vehicle, and can be better in the bumps. Stiffer springs will increase corner speed if traction is available and will also tend to jump and land better. Once you find a set of springs you like you will typically only change them for tracks with dramatically different conditions.

## Pistons



Pistons with smaller holes work well for smoother tracks with large jumps and pistons with larger holes work well for rougher tracks with less jumps. Smaller hole pistons will typically use thinner oil than larger hole pistons. Shock oil is also affected by the ambient temperature so a change in viscosity might be necessary with a change of 5°C or ~10°F.

## Sway Bars

Part#	F/R	Size
TKR6623	Front	1.0mm
TKR6623	Front	1.1mm
TKR6623	Front	1.2mm
TKR6623	Front	1.3mm
TKR6623	Front	1.4mm
TKR6610	Rear	1.5mm
TKR6610	Rear	1.6mm
TKR6610	Rear	1.7mm
TKR6610	Rear	1.8mm
TKR6610	Rear	1.9mm

Sway bars are used to adjust a vehicle's lateral grip by resisting chassis roll. A thicker bar decreases roll more than a thinner bar will. More roll means more grip and less roll means less grip. The front sway bar affects mainly off-power steering at corner entry. The rear sway bar affects mainly on-power steering and stability in mid-corner and at corner exit.

## Bearing Chart

	<b>TKRBB040725</b> – Ball Bearings (4x7x2.5mm, sold in pack of 4pcs) Bearings for the bellcrank/ackerman plate. 8pcs required in kit.
	<b>TKRBB05114</b> – Ball Bearings (5x11x4, 4pcs) Diff pinion support bearings for the front/rear transmission housings. 4pcs required in kit.
	<b>TKRBB06124</b> – Ball Bearings (6x12x4mm, 4pcs) Bearings for outside of steering blocks and outer rear hub carriers. 4pcs required in kit.
	<b>TKRBB10154</b> – Ball Bearings (10x15x4mm, sold in pack of 4pcs) Bearings for all three diffs. Also inner front steering blocks/rear hub carriers. 10pcs required in kit.

\* For bearing maintenance, please refer to page 28.

## Gearing Recommendations



Vehicle	Motor	Small Track	Large Track
		(pinion/spur) (50-80 ft Straight)	(pinion/spur) (80-150 ft Straight)
EB410 (2 cell)	5.5T	18/81 tooth	19/81 tooth
	6.5T	19/81 tooth	20/81 tooth
	7.5T	20/81 tooth	21/81 tooth
	8.5T	20/76 or 21/81	21/76 or 22/81
	10.5T	21/76 or 22/81	22/76 or 23/81
	13.5T	25/70 tooth	26/70 tooth

This chart shows the recommended starting ratios for the common motor winds. Please consult the motor/esc manufacturers recommended settings to ensure you start with the best final drive ratio (FDR) for your equipment. When setting your mesh you want to be able to *slightly* rock the spur gear back and forth without moving the pinion gear. Tekno RC is not responsible for damage done to your electronic equipment or gears due to improper gearing or mesh.

# Maintenance:

Performing regular maintenance will greatly improve your on track consistency and also extend the life of your vehicle. Going through critical areas of the vehicle regularly will also allow you to find possible issues before they become a problem that may cost you a race. Follow the guidelines below for maximum performance.

## Bearing Maintenance:

Bearings should always be smooth and free in order to perform their function. We recommend inspecting and cleaning each bearing on a regular basis. It will be necessary to break down parts of the vehicle in order to inspect them properly. The procedures below should be done every couple of weeks or prior to an important race.

1. Inspect the outer seals for any visible damage and check the rolling resistance of each bearing.
2. If any bearing does not spin freely, then take the following steps to clean them.
3. Spray the bearing with motor spray and spin it again to remove any debris trapped inside. Repeat if necessary. If the bearing does not start to spin freely after cleaning, then they may need to be replaced.
4. Allow the clean bearing to dry or blow into the bearing with compressed air to speed up the drying process.
5. Oil each bearing with a proper bearing lubricant. One or two drops is enough.

## Shock Maintenance:

When comparing the left and right shocks of the front end, they should feel identical. Same goes for the rears. The procedures below should be done every race day to make sure they are leak free and operating correctly.

1. After removing the shocks from the vehicle, remove the springs and inspect each shock for visible leaks (build up of debris at the bottom of the shock shaft or visible oil).
2. If the shock binds when pushing the shaft through its stroke, then the shaft may be bent and will need to be replaced.
3. If the shocks from left to right do not feel consistent when compared to each other, or have built up too much air inside (feel empty when pushing the shaft through its stroke), then you will need to rebuild them following the steps outlined on page 19 of this manual.

## Hinge Point & Drive Line Maintenance:

Checking the hinge points while the shocks are removed from the vehicle is the best time to inspect these parts. The other items to inspect are the camber links, steering links and drive shafts. Follow the steps below every couple of weeks in order to keep the vehicle performing at maximum.

1. With the shocks off the vehicle, check the movement of the arms, hubs and spindle carriers. They should move freely. If there is a bind, then the inner or outer hinge pin may be bent and would need to be replaced. The arms should not have any play when twisted or moved in any direction against the hinge points. If there is excessive slop present, then the arms or hubs may be worn and will need to be replaced.
2. Remove the camber links, steering links and servo link from the vehicle. Check the movement of the spindles to see if they turn freely. If they don't, then check the kingpin shoulder screws to see if they are tightened down too far. Also, check for slop. If there is excessive slop present, then the spindle carriers may need to be replaced.
3. Check the steering rack to make sure it moves freely. If it binds, then the screws holding the Ackermann or the steering posts could be too tight. If they still bind, then check the bearings and follow the steps above to clean them.
4. After re-installing the camber links, steering links and servo link, check the movement of the rod ends on the ball studs. If they have excessive slop or are binding, then they may need to be replaced.
5. Check the drive shafts by rotating them. Look for any wobbles. If they are bent, replace them immediately.
6. With the drive shafts removed, check for slop in the CV area. If it is present, then reposition the CV pin to another fresh hole, re-lubricate and install back into the vehicle.

## Differential Maintenance:

Properly maintained differentials are essential for a smooth operating vehicle. Check all three diffs regularly to make sure they are filled and operating as designed.

1. Remove each diff and verify the differential action is happening and is smooth. If there is any notchy feel to them, follow the steps below to rebuild them.
2. Open the diff and pour out the oil. Remove the gears and pins to release the outdrives. Then remove the seals. Inspect everything to make sure there are no damaged parts. If the seals are old or show any signs of degradation, replace them immediately. Re-lubricate the seals and outdrives, then rebuild the diff following the steps on page 3 and 4.

# TKR6500 - EB410 1/10th Competiton 4x4 Buggy Complete Kit

## Parts List

TKR5125 - O-Ring (ESC tray, 3pcs)  
TKR5126 - Antenna tube (universal, w/ caps, 5pcs)  
TKR5230 - Steering linkage (M3x18mm threaded rod, 10pcs)  
TKR5571M - Wheel Hexes (12mm, steel, lightened, 4pcs)  
TKR6206 - Ball Stud (5.5mm, short neck, 6mm thread, 4pcs)  
TKR6207 - Ball Stud (5.5mm, long neck, 6mm thread, 4pcs)  
TKR6208 - Ball Stud (5.5mm, short neck, 8mm thread, 4pcs)  
TKR6210 - Ball Stud (5.5mm, short neck, 10mm thread, 4pcs)  
TKR6250 - Turnbuckle (M3 thread, 55mm length, 4mm adjustment, 2pcs)  
TKR6252 - Turnbuckle (M3 thread, 40mm length, 4mm adjustment, 2pcs)  
TKR6253 - Rod End Set (turnbuckles, sway bar, steering, EB410)  
TKR6270R - Stub Axles (rear, hardened steel, EB410, 2pcs)  
TKR6274 - Wheel Nuts (7mm, serrated, gun metal ano, M4, 4pcs)  
TKR6280 - Battery Strap Thumb Screw (EB410)  
TKR6501 - Chassis (7075, 3mm, hard anodized, lightened, EB410)  
TKR6519 - Bulkhead Set (f/r, EB410)  
TKR6523 - Hinge Pins (inner, front/rear, super hard, EB410, 2pcs)  
TKR6524 - Suspension Arms (rear, EB410)  
TKR6525 - Suspension Arms (front, EB410)  
TKR6526 - Bell Cranks, Ackerman Plate, Servo Horns (EB410)  
TKR6527 - Shock Standoffs (EB410, 2pcs)  
TKR6530 - Motor Mount Base (CNC, 7075, EB410)  
TKR6538 - Chassis Brace, Body Mount Set (EB410)  
TKR6539 - Motor Mount Insert (CNC, 7075, EB410)  
TKR6540 - Hinge Pin Brace (CNC, 7075, EB410, A Block)  
TKR6541 - Hinge Pin Brace (CNC, 7075, EB410, B Block)  
TKR6542 - Hinge Pin Brace (CNC, 7075, EB410, C Block)  
TKR6543 - Hinge Pin Brace (CNC, 7075, EB410, D Block)  
TKR6544 - Hinge Pin Inserts, Wheelbase Shims (EB410)  
TKR6545 - Rear Hubs (l/r, EB410)  
TKR6546 - Wing Mount and Bumper (EB410)  
TKR6547 - Sway Bar and Bulkhead Acc. (EB410)  
TKR6548 - Pivot Balls (5.5mm, flanged, 4pcs)  
TKR6552 - Spindle Carriers (l/r, EB410)  
TKR6553 - Spindles (15°, l/r, EB410)  
TKR6555 - Stabilizer Balls (5.5mm, sway bars, aluminum, 4pcs)  
TKR6565 - Hinge Pins (outer, front, EB410, 2pcs)  
TKR6566 - Hinge Pins (outer, rear, EB410, 2pcs)  
TKR6572 - Driveshaft (rear, hardened steel, 2pcs)  
TKR6573F - Stub Axles (front, hardened steel, EB410, 2pcs)  
TKR6574 - Driveshaft (front, hardened steel, 2pcs)  
TKR6581 - Shock Tower Set (f/r, EB410)  
TKR6586 - Side Guard, Servo Mount, Battery Acc. (EB410)  
TKR6596 - Kingpin Shoulder Screws (EB410, 4pcs)  
TKR6597 - Diff Coupler (f/r, lightened, hardened steel, EB410)  
TKR6599 - Tapered Driveshaft (center, rear, 7075, black ano, EB410)  
TKR6600 - Tapered Driveshaft (center, front, 7075, black ano, EB410)  
TKR6605 - Wing (lexan, pre-cut, EB410)  
TKR6608 - Body (0.8mm, EB410)  
TKR6610 - Sway Bar Set (rear, 1.5, 1.6, 1.7, 1.8, 1.9mm, EB410)  
TKR6627 - Steering Rack Bushings (aluminum, EB410, 2pcs)  
TKR6629 - Steering Posts (steel, EB410, 2pcs)  
TKR6634 - Center Diff Support, Top Braces (EB410)  
TKR6664 - Front Camber Link Plate (aluminum, EB410)  
TKR6665 - Rear Camber Link Plate (aluminum, EB410)  
TKR6685 - Rear Body Mount Panels (EB410, 2pcs)  
TKR6686 - Body Mount Hook and Loop Tape Set (EB410, 4pcs)  
TKR6856 - CV Rebuild kit (f/r, for 2 axles)

## Differential List

TKR5144 - Differential O-Rings (6pcs)  
TKR6511 - Differential Case (f/c/r, 3pcs, EB410)  
TKR6512 - Differential Ring Gear (40t, use with TKR6551)  
TKR6513X - Differential Cross Pins (composite, 3pcs, EB410)  
TKR6514 - Differential Outdrives (f/r/c, lightened, EB410)  
TKR6515 - Differential Seals (3pcs, EB410)  
TKR6517 - Differential Shims (5x14mm, hardened, 6pcs, EB410)  
TKR6522 - Spur Gear (81t, 48pitch, composite, black, EB410)  
TKR6550 - Differential Gear Set (internal gears only, EB410)  
TKR6551 - Diff Pinion (16t, use with TKR6512)

## Bearings List

TKRBB040725 - Ball Bearing (4x7x2.5mm, 4pcs)  
TKRBB05114 - Ball Bearing (5x11x4, 4pcs)  
TKRBB06124 - Ball Bearing (6x12x4, 4pcs)  
TKRBB10154 - Ball Bearing (10x15x4, 4pcs)

## Shocks List

TKR6701 - Locking Shock Rod End and Spring Perch Set (13mm shocks)  
TKR6703 - Shock Shafts (front, steel, EB410, 2pcs)  
TKR6704 - Shock Shafts (rear, steel, EB410, 2pcs)  
TKR6707 - Shock Cartridge End Guide Set (CNC, Delrin, 4pcs, EB410)  
TKR6709 - Shock X-rings (8pcs, EB410)  
TKR6710 - Shock Body (front, aluminum, hard ano, EB410, 2pcs)  
TKR6711 - Shock Body (rear, aluminum, hard ano, EB410, 2pcs)  
TKR6712 - Shock/Cartridge Cap & Bushing Set (4pcs each, EB410)  
TKR6714 - Emulsion O-ring Set (4x cap seals, 8x emulsion o-rings, for 13mm shocks)  
TKR6719A - Shock Adjustment Collars (aluminum, EB410, 2pcs)  
TKR6785 - Shock Spring Set (front, 1.3x8.5, 3.41lb/in, 45mm, yellow)  
TKR6795 - Shock Spring Set (rear, 1.2x8.25, 2.6lb/in, 53mm, yellow)

## Hardware List

TKR1201 - M3 Locknuts (black, 10pcs)  
TKR1211 - M3 Locknuts (flanged, black, 10pcs)  
TKR1221 - M3x8mm Washer (black, 10pcs)  
TKR1229 - 6x10x.2 Shims (10pcs)  
TKR1235 - Body Clips (angled, 10pcs)  
TKR1240 - Lower Shock Mount Screws (2 CW thread, 2 CCW thread)  
TKR1245 - Shock Piston Retainer Screw (4pcs)  
TKR1248 - M2x4mm Cap Head Screws (black, 10pcs)  
TKR1301 - M2.5x6mm Flat Head Screws (black, 10pcs)  
TKR1303 - M2.5x10mm Flat Head Screws (black, 10pcs)  
TKR1321 - M3x6mm Flat Head Screws (black, 10pcs)  
TKR1322 - M3x8mm Flat Head Screws (black, 10pcs)  
TKR1323 - M3x10mm Flat Head Screws (black, 10pcs)  
TKR1329 - M3x20mm Flat Head Screws (black, 10pcs)  
TKR1400 - M3x4mm Button Head Screws (black, 10pcs)  
TKR1401 - M3x6mm Button Head Screws (black, 10pcs)  
TKR1402 - M3x8mm Button Head Screws (black, 10pcs)  
TKR1403 - M3x10mm Button Head Screws (black, 10pcs)  
TKR1405 - M3x14mm Button Head Screws (black, 10pcs)  
TKR1409 - M3x20mm Button Head Screws (black, 10pcs)  
TKR1411 - M3x25mm Button Head Screws (black, 10pcs)  
TKR1463 - M2.5x6mm Button Head Screws (black, 10pcs)  
TKR1522 - M3x8mm Cap Head Screws (black, 10pcs)  
TKR1523 - M3x10mm Cap Head Screws (black, 10pcs)  
TKR1601 - M3x4mm Set Screws (black, 10pcs)  
TKR1602 - M4x4mm Set Screws (black, 10pcs)  
TKR1604 - M3x8mm Set Screws (black, 10pcs)  
TKR1609 - M3x3mm Set Screws (black, 10pcs)  
TKR1611 - M4x8mm Set Screws (black, 10pcs)

## Option Parts

TKR1103 - Turnbuckle Wrench (4mm, 5mm, hardened steel)  
TKR1115 - Pivot Ball and Shock Multi-tool (aluminum)  
TKR1119 - 5.5mm / 7.0mm Wrench (hardened steel)  
TKR1654 - Composite 12mm Hex Adapters (+1mm, 4pcs)  
TKR1654X - 12mm Aluminum Hex Adapters (+1mm, aluminum, 4pcs)  
TKR5571 - Composite Wheel Hexes (12mm, 4pcs)  
TKR5571A - Wheel Hexes (SCT410, 12mm, aluminum, 4pcs)  
TKR6503C - Battery Strap (carbon fiber, EB410)  
TKR6542B - Hinge Pin Brace (CNC, 7075, C Block for diff riser, EB410)  
TKR6543B - Hinge Pin Brace (CNC, 7075, D Block for diff riser, EB410)  
TKR6563A - Aluminum Servo Horn (25T, standard, low profile, M3 clamp, EB410)  
TKR6581C - Shock Tower (front, carbon fiber, EB410)  
TKR6582C - Shock Tower (rear, carbon fiber, EB410)  
TKR6582XC - Shock Tower (rear, 2mm riser, carbon fiber, EB410)  
TKR6598C - Steering Top Plate (carbon fiber, EB410)  
TKR6610 - Sway Bar Set (rear, 1.5, 1.6, 1.7, 1.8, 1.9mm, EB410)  
TKR6623 - Sway Bar Kit (complete front, 1.0, 1.1, 1.2, 1.3, 1.4mm, EB410)  
TKR6635C - Center Diff Top Plate and Fan Mount (carbon fiber, EB410)  
TKR6703T - Shock Shafts (front, steel, TiNi coated, EB410, 2pcs)  
TKR6704T - Shock Shafts (rear, steel, TiNi coated, EB410, 2pcs)  
TKR6712A - Shock Caps (7075, emulsion, black ano, 2pcs)  
TKR6731 - Shock Pistons (CNC, 2x1.7, 2pcs)  
TKR6732 - Shock Pistons (CNC, 2x1.8, 2pcs)  
TKR6783 - Shock Spring Set (front, 1.3x9.5, 2.95lb/in, 45mm, pink)  
TKR6784 - Shock Spring Set (front, 1.3x9.0, 3.16lb/in, 45mm, green)  
TKR6786 - Shock Spring Set (front, 1.3x8.13, 3.62lb/in, 45mm, orange)  
TKR6787 - Shock Spring Set (front, 1.3x7.75, 3.85lb/in, 45mm, red)  
TKR6793 - Shock Spring Set (rear, 1.2x9.38, 2.20lb/in, 53mm, pink)  
TKR6794 - Shock Spring Set (rear, 1.2x8.75, 2.41lb/in, 53mm, green)  
TKR6796 - Shock Spring Set (rear, 1.2x7.75, 2.82lb/in, 53mm, orange)  
TKR6797 - Shock Spring Set (rear, 1.2x7.38, 3.02lb/in, 53mm, red)

Name:  Box Setup (starting point)

Date:

Event:

Track: Indoor  Outdoor  Size: Small  Medium  Large  Traction: Low  Med  High

Surface: Smooth  Bumpy  Rutted  Type: Dirt  Clay  Carpet  AstroTurf

Condition: Dusty  Dry  Wet  Muddy

## Bumpsteer/Ackermann/Steering Stop:



### Front End:

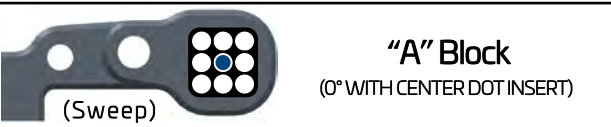
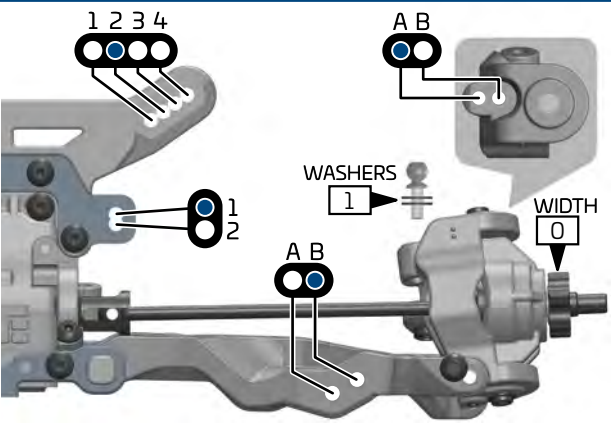

### Rear End:

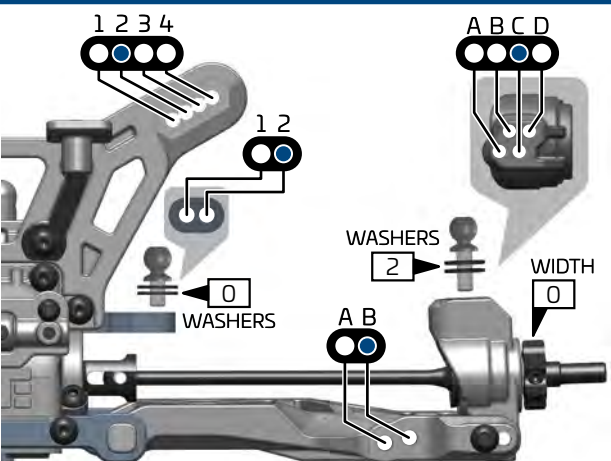

## Suspension:

	FRONT	REAR
RIDE HEIGHT	18mm	21mm
CAMBER	-2°	-2°
CASTER	15°	
SWEEP	0°	
KICK UP	10.5°	
ANTI-SQUAT		2°
TOE (in/out)	1.5° out (per side)	1.5° in (per side)
SWAY BAR	none	1.7mm
SHOCK LENGTH (DROOP)	78	88

## Shocks:

	FRONT	REAR
OIL	500	500
BRAND	Stock	Stock
PISTON	1.7	1.8
SPRING	Yellow	Yellow
REBOUND	5 %	5 %
BUILD	Emul	Emul

NOTES:

## Tires / Wheels:

	FRONT	REAR
BRAND/TREAD		
COMPOUND		
INSERT		
WHEEL		

NOTES:

## Differential Oil:

FRONT	CENTER	REAR
15K	15K	7K

## Electronics:

ESC:	
BATTERY:	
MOTOR:	
RADIO:	
SERVO:	

## Drivetrain:

PINION/SPUR	81
-------------	----

## Chassis Braces:

Short Rear  Long Rear

## Body/Wing:

BODY/WING	STOCK	STOCK
-----------	-------	-------

### DOWNFORCE SETTINGS

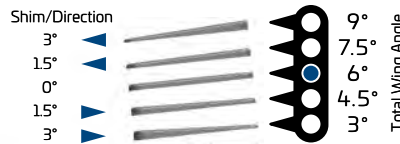

## Wheelbase/Axle Sweep:

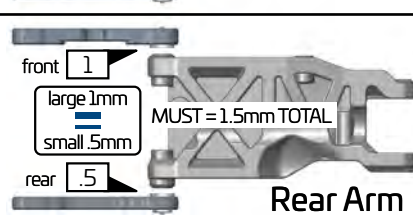
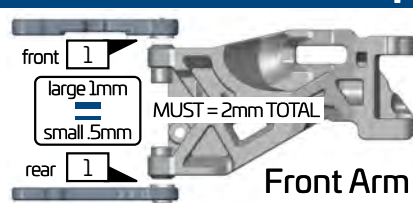

## Notes:

**Name:** \_\_\_\_\_ **Date:** \_\_\_\_\_ **Event:** \_\_\_\_\_

**Track:** Indoor  Outdoor  **Size:** Small  Medium  Large  **Traction:** Low  Med  High

**Surface:** Smooth  Bumpy  Rutted  **Type:** Dirt  Clay  Carpet  AstroTurf

**Condition:** Dusty  Dry  Wet  Muddy

### Bumpsteer/Ackermann/Steering Stop:



### Front End:

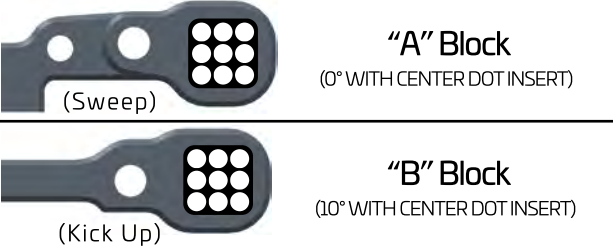
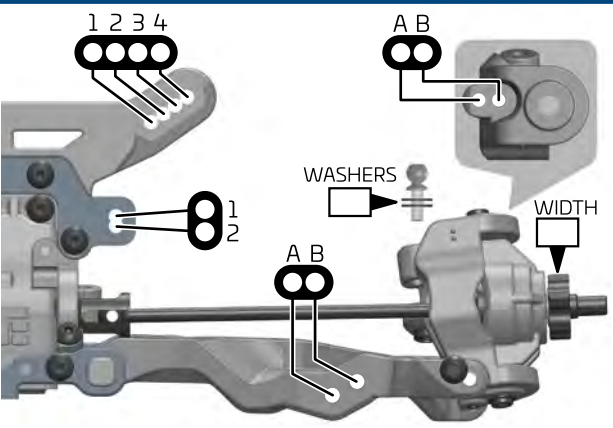

### Rear End:

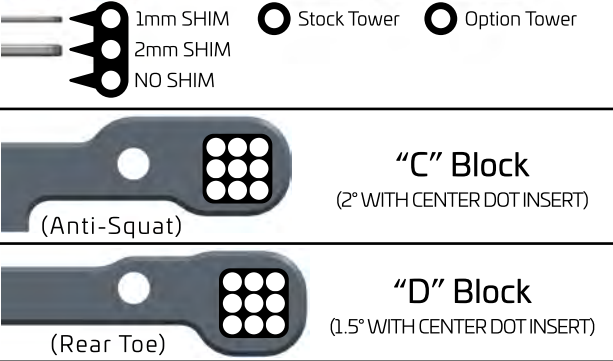
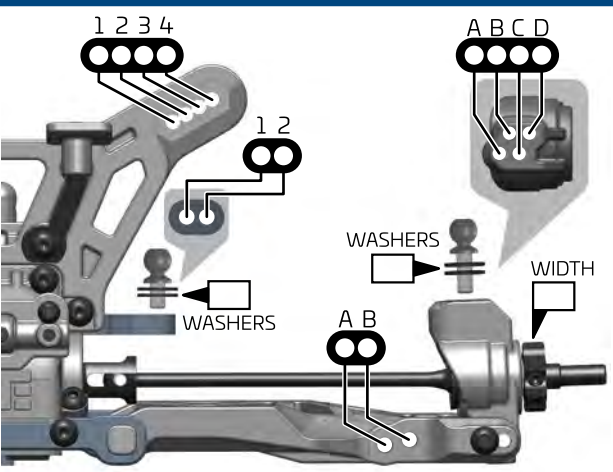

### Suspension:

	FRONT	REAR
RIDE HEIGHT		
CAMBER		
CASTER		
SWEEP		
KICK UP		
ANTI-SQUAT		
TOE (in/out)	(per side)	(per side)
SWAY BAR		
SHOCK LENGTH (DROOP)		

### Shocks:

	FRONT	REAR
OIL		
BRAND		
PISTON		
SPRING		
REBOUND	%	%
BUILD		
NOTES:		

### Tires / Wheels:

	FRONT	REAR
BRAND/TREAD		
COMPOUND		
INSERT		
WHEEL		
NOTES:		

### Body/Wing:

**DOWNFORCE SETTINGS**

Shim/Direction: 3°, 15°, 0°, 15°, 3°

Total Wing Angle: 9°, 7.5°, 6°, 4.5°, 3°

**WING POSITION SETTINGS**

(rear) (front)

### Differential Oil:

FRONT	CENTER	REAR

### Electronics:

ESC:	
BATTERY:	
MOTOR:	
RADIO:	
SERVO:	

### Drivetrain:

PINION/SPUR	
-------------	--

### Chassis Braces:

Short Rear  Long Rear

### Wheelbase/Axle Sweep:

**Front Arm**

front rear

large 1mm small .5mm

MUST = 2mm TOTAL

**Rear Arm**

front rear

large 1mm small .5mm

MUST = 1.5mm TOTAL

### Notes:

\_\_\_\_\_

\_\_\_\_\_

\_\_\_\_\_

\_\_\_\_\_



Tekno RC  
10755 Scripps Poway Pkwy #598  
San Diego CA 92131  
USA

[www.teknorc.com](http://www.teknorc.com)

